



## Natural Soil Properties

Step 1.



**Dry sand has no load carrying capability**

3

## How does Soil Reinforcement Work ??

Step 2.



**Arrange pine needles in parallel direction  
and place soil over them**

4

### How does Soil Reinforcement Work ??

Step 3.



Repeat process to form layers

5

### How does Soil Reinforcement Work ??

Step 4.



Conduct a load test

6

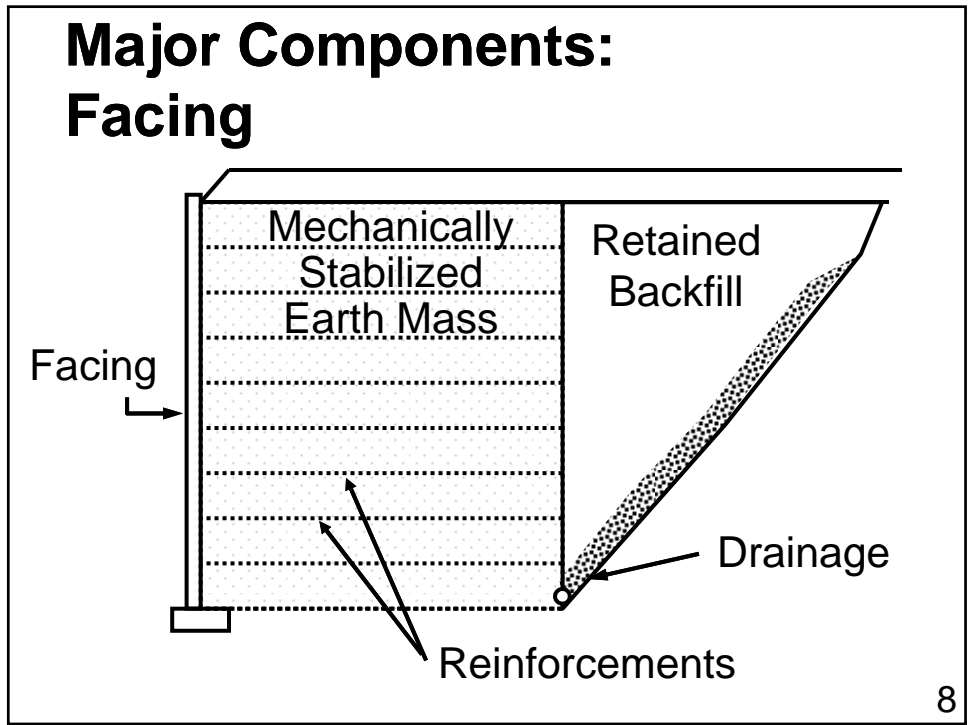
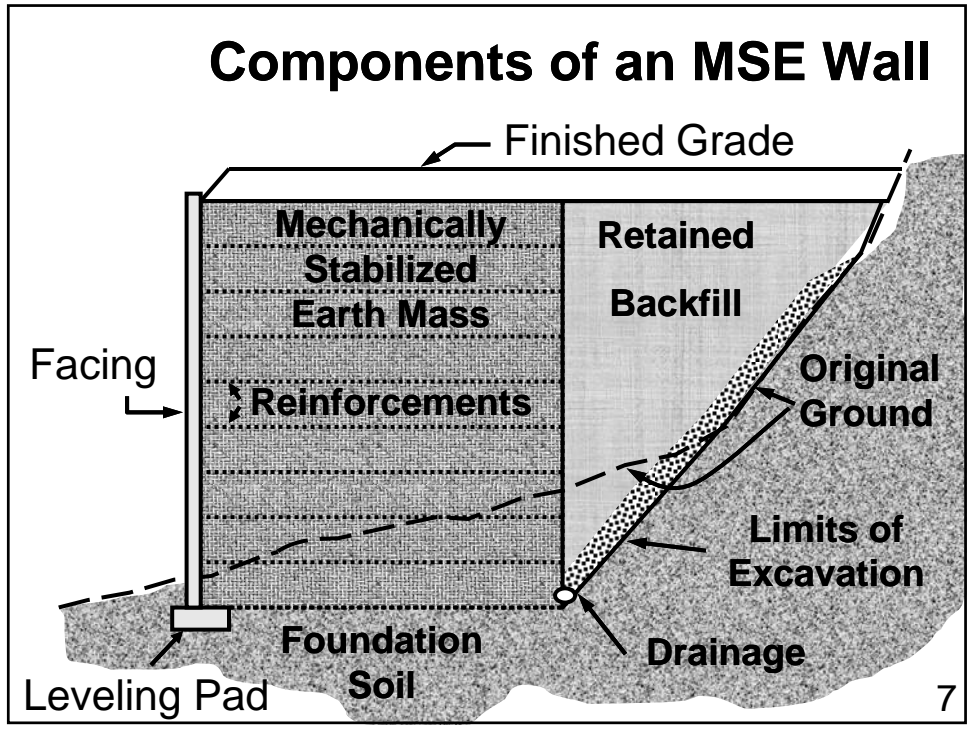

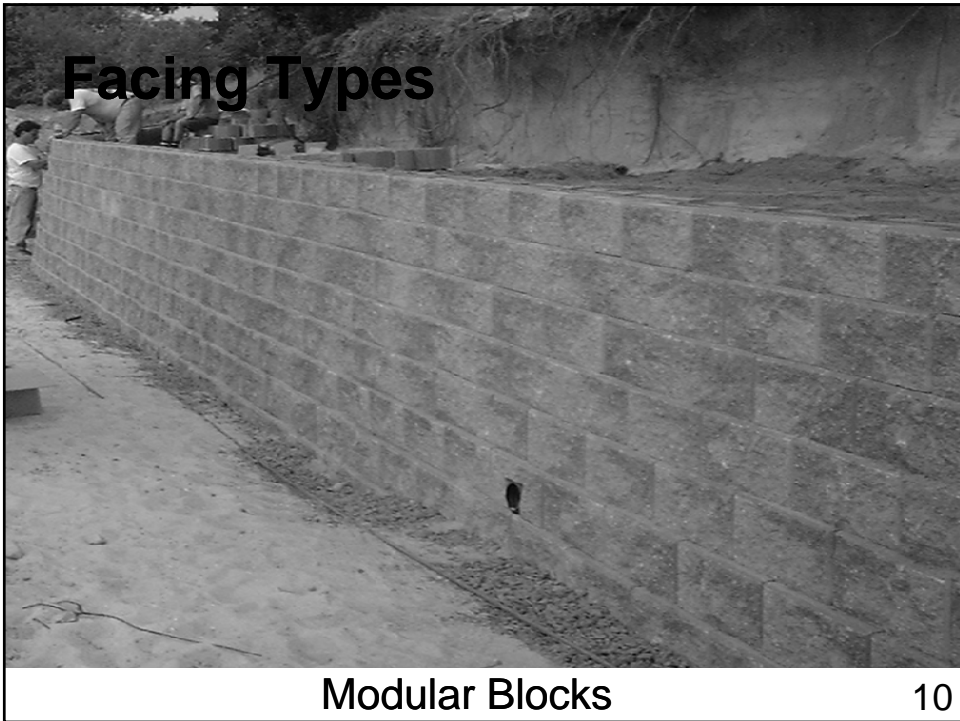
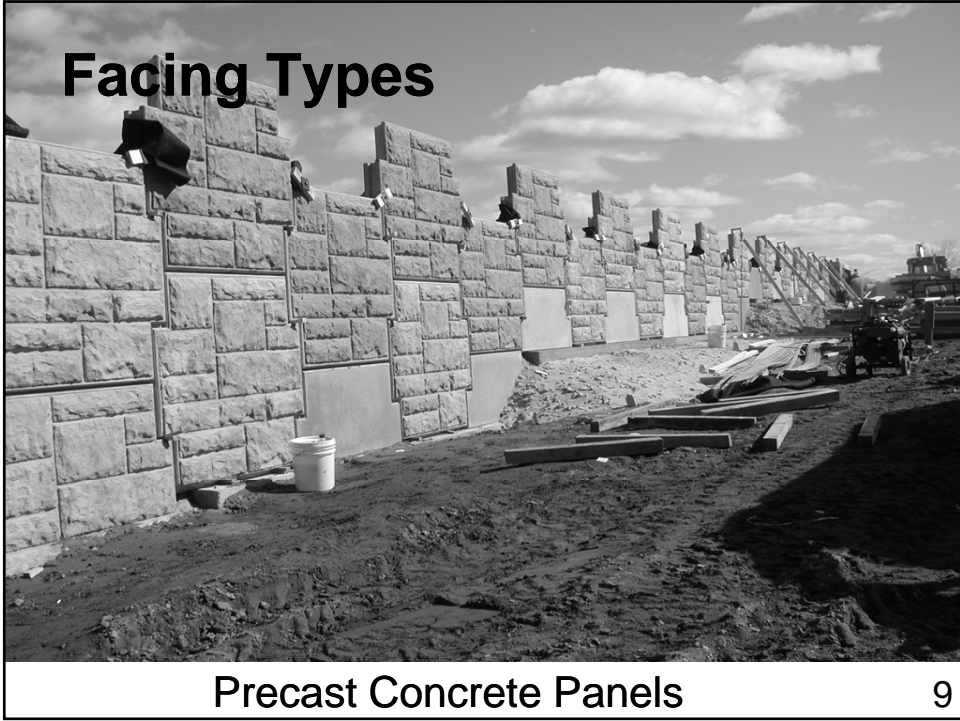

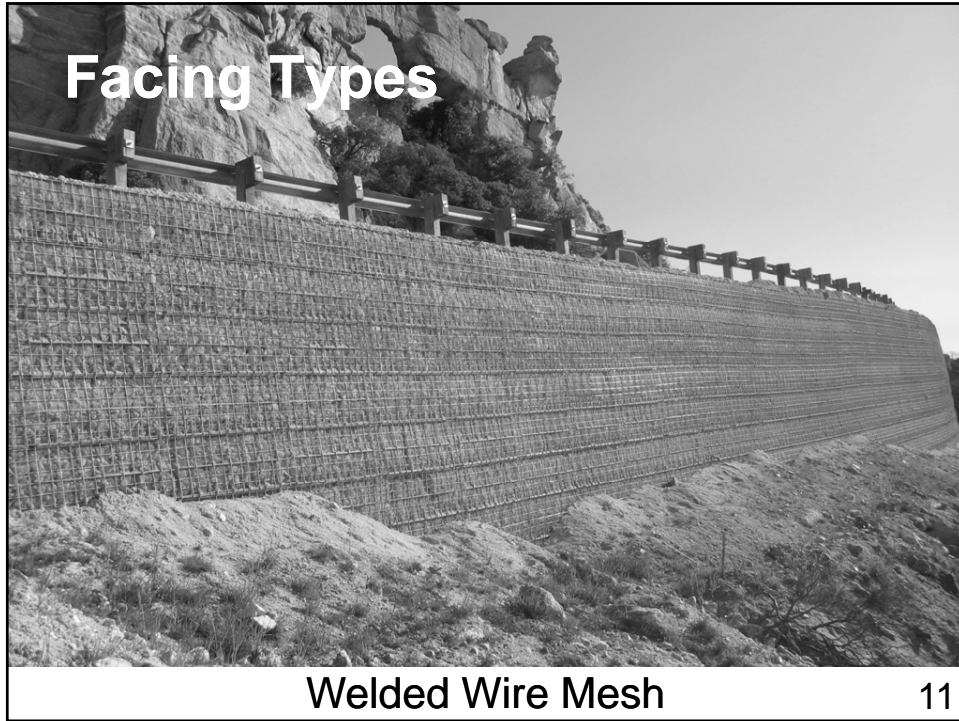

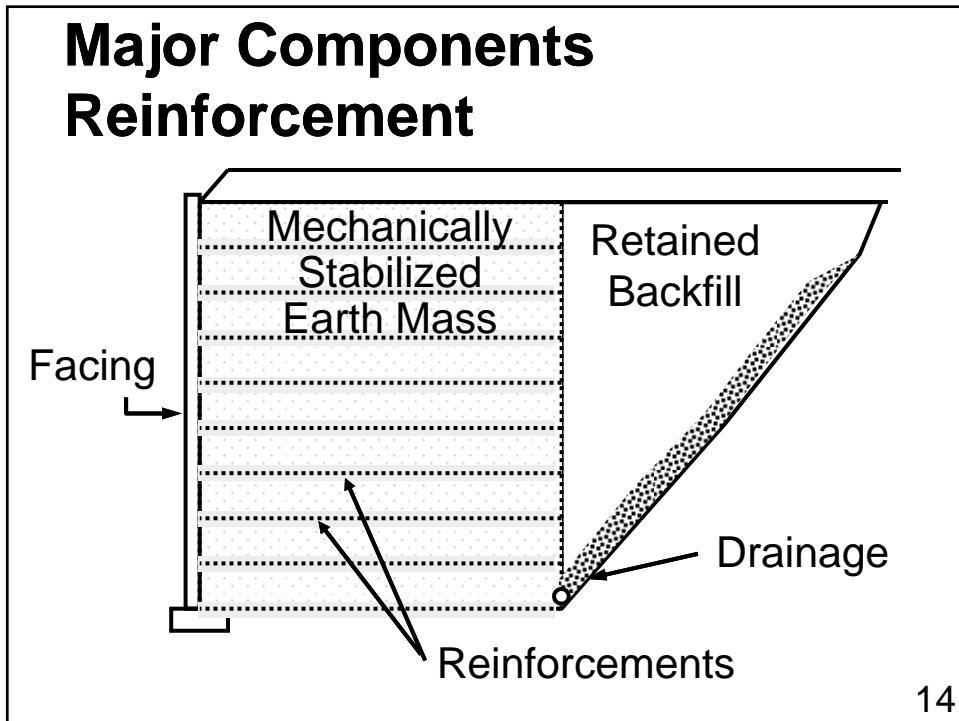

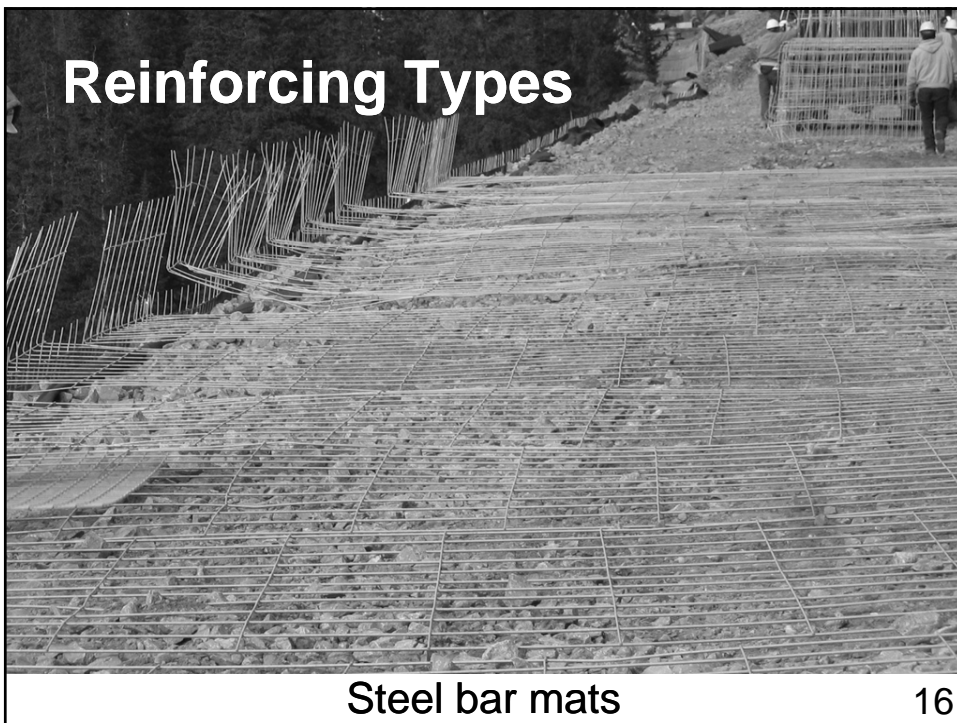

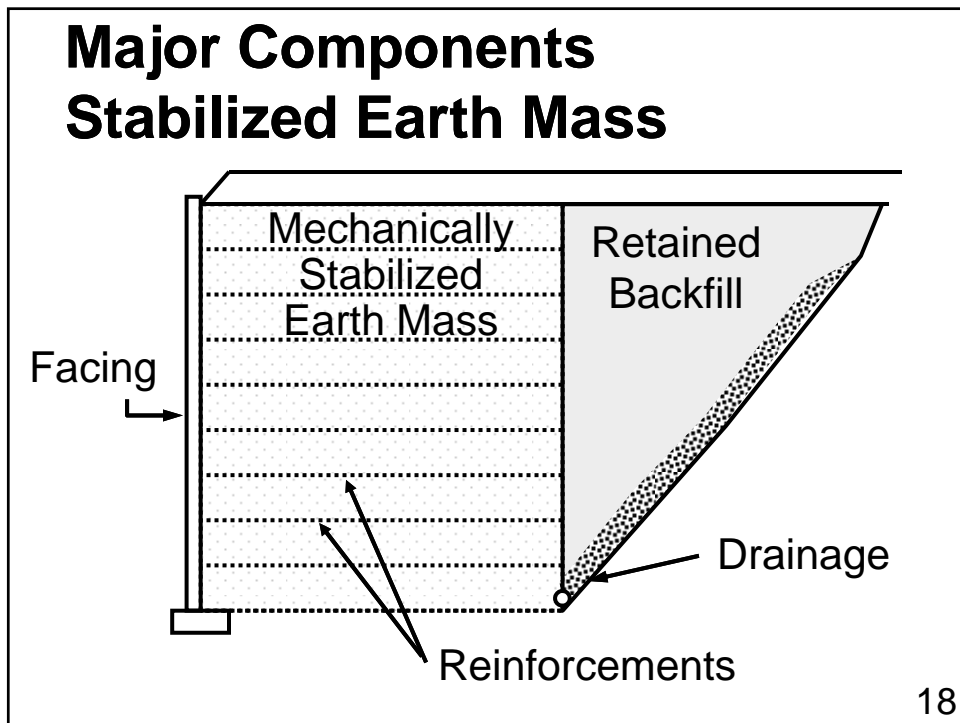
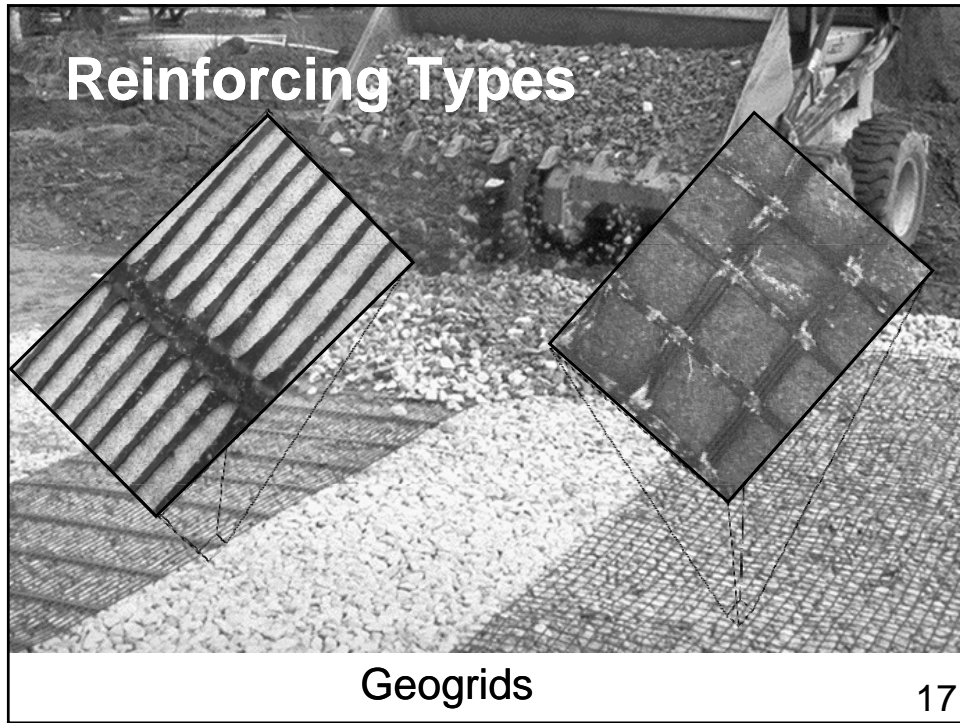

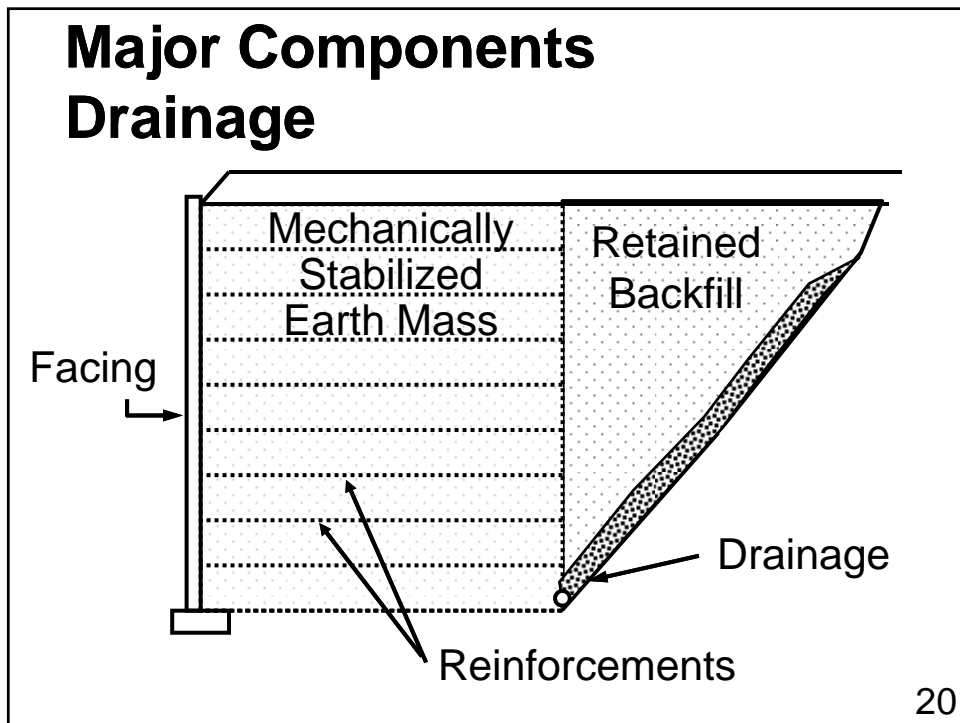
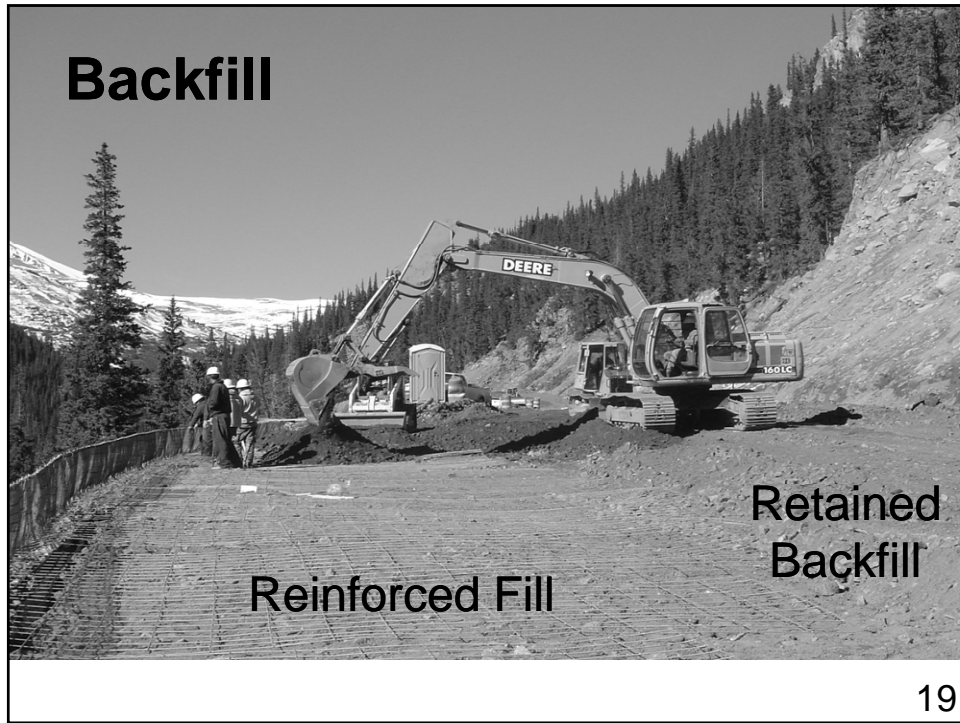



# Uses of MSE walls

22

## Retaining Walls



23



## Retaining Walls

24

# Abutments



25

# Abutments



26

## Abutments



27

## Wing Walls - Rail



28

## Landslide Repair



29

## Crash Walls



30

## Pedestrian Ramps



31

## Phased Construction



32

## Phased Construction



33

# MSE Design Concepts

34

## MSE Wall as a Gravity Wall

- An MSE wall is a gravity wall.

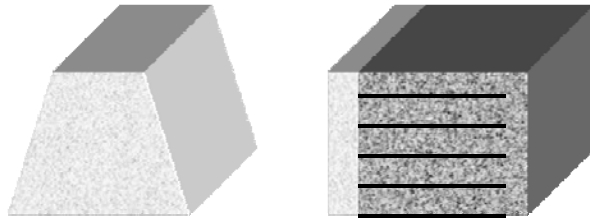

Heavy walls  
are good

35

## MSE Wall as a Gravity Wall

- Design evaluations treat the reinforced soil mass as a rigid block
- Evaluate the external stability according to conventional failure modes for gravity type wall systems

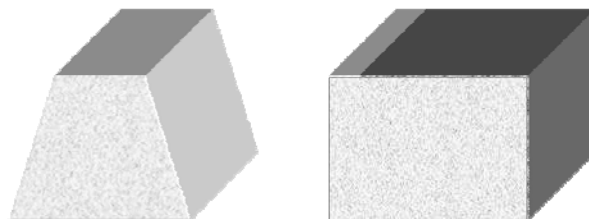

36

### External Stability

- Bearing resistance
- Settlement
- Sliding
- Overturning
- Overall Stability

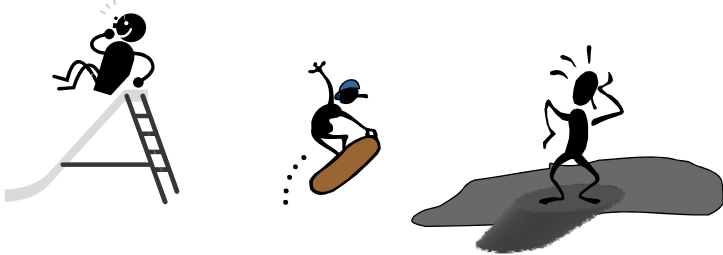

The illustration shows three stick figures. The first is falling backwards from a ladder. The second is on a skateboard, performing a trick. The third is standing on a large, flat rock, looking surprised.

37

### External Stability

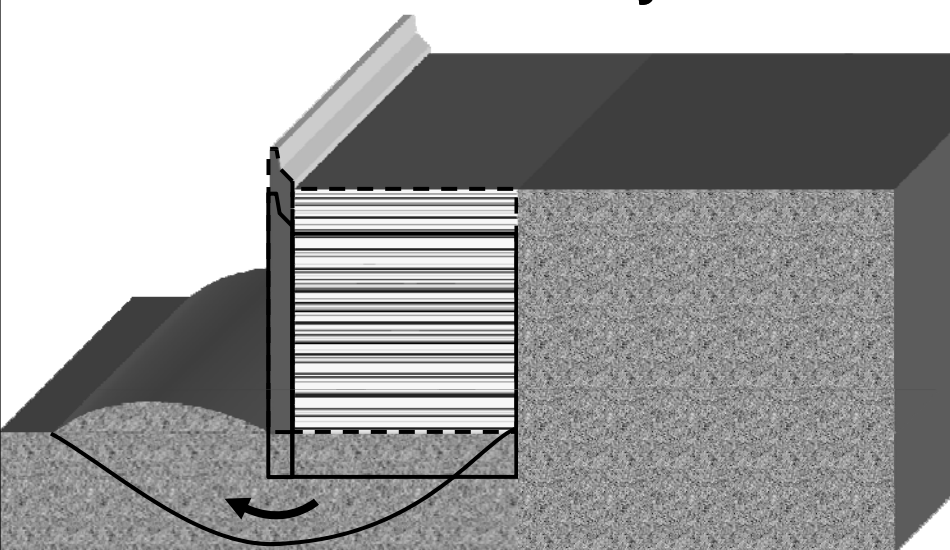

The diagram shows a cross-section of a building with a roof and a wall. The wall is supported by a foundation. Below the foundation, there is a layer of soil. A curved arrow indicates the soil's bearing capacity. The word "Bearing" is written below the diagram.

Bearing

38

## Bearing Failure



39

## External Stability

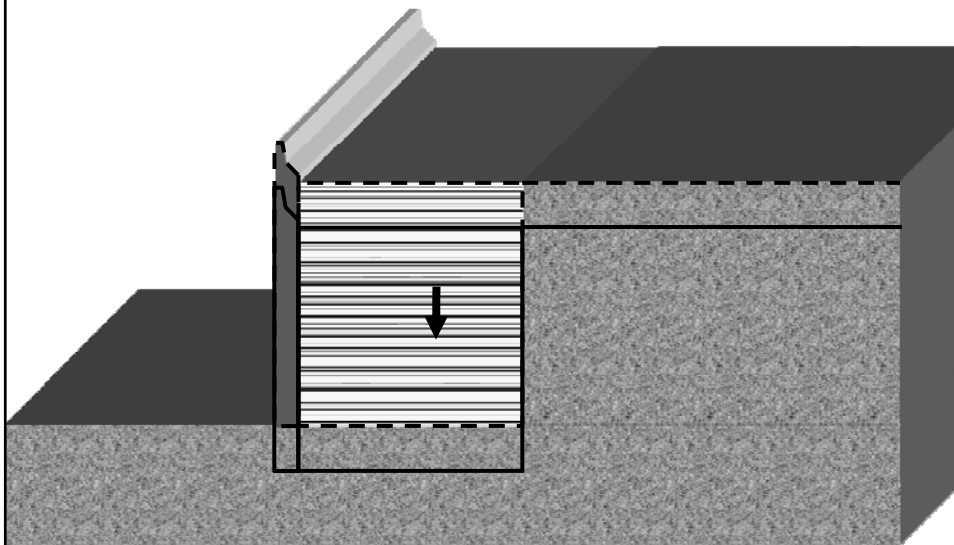

Settlement

40

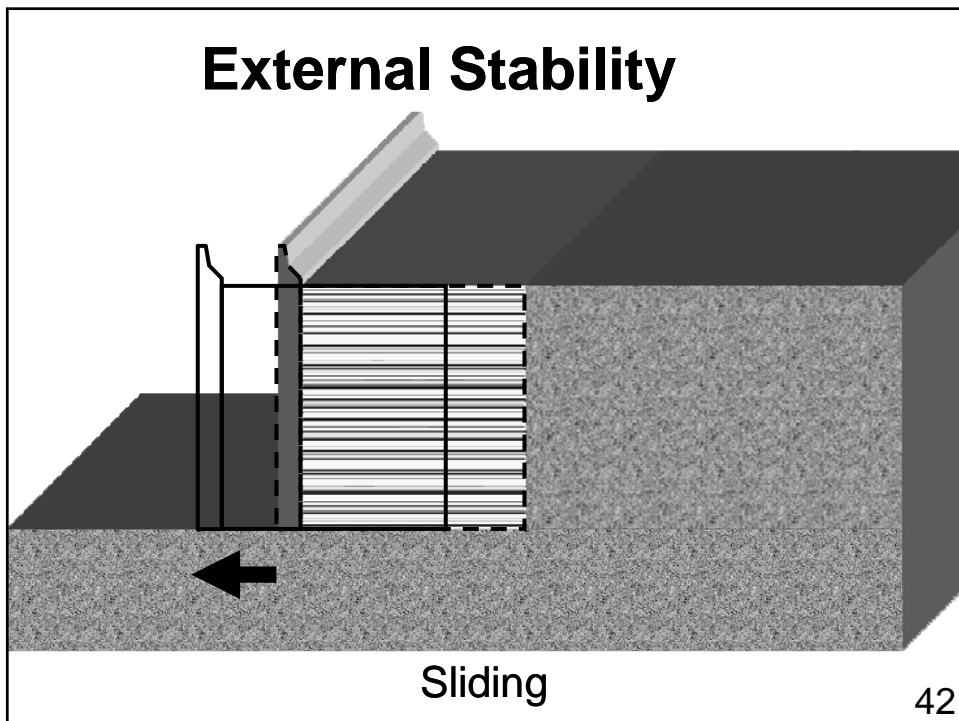

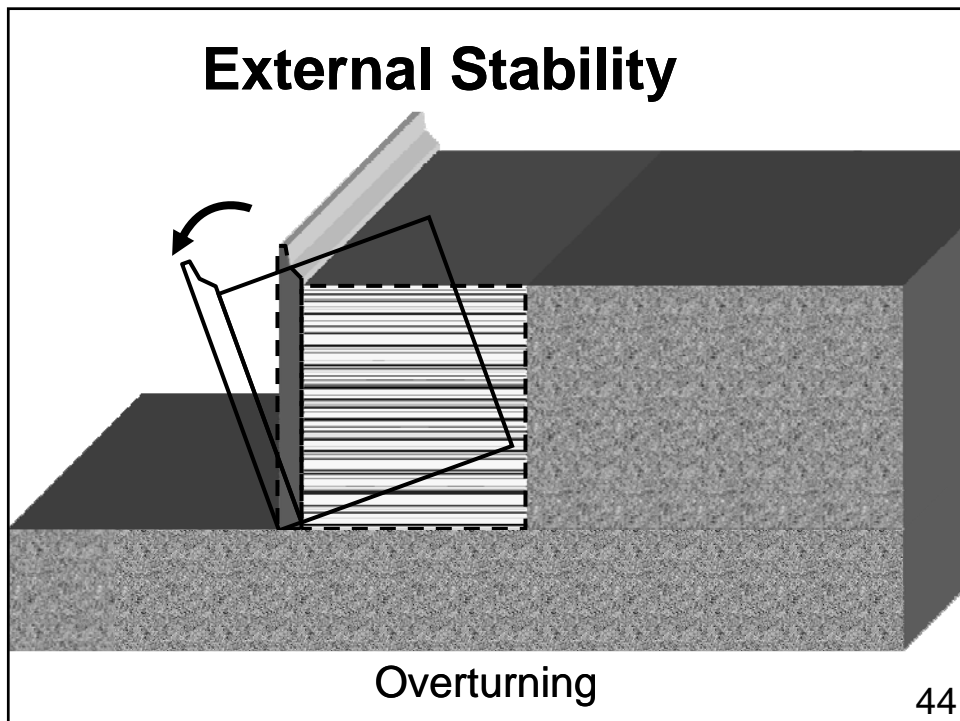
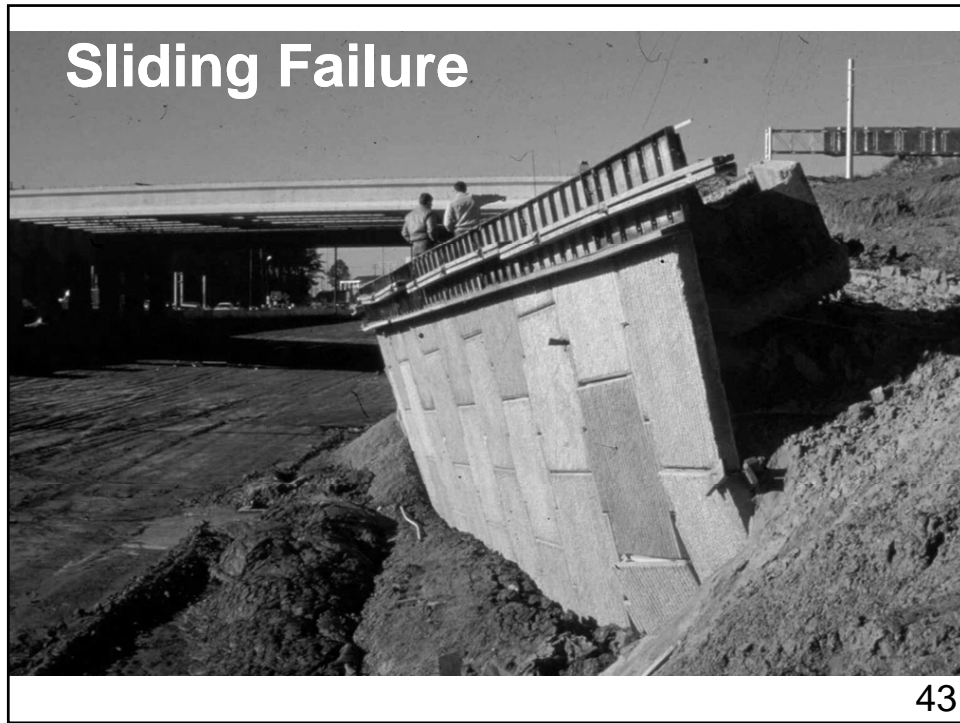

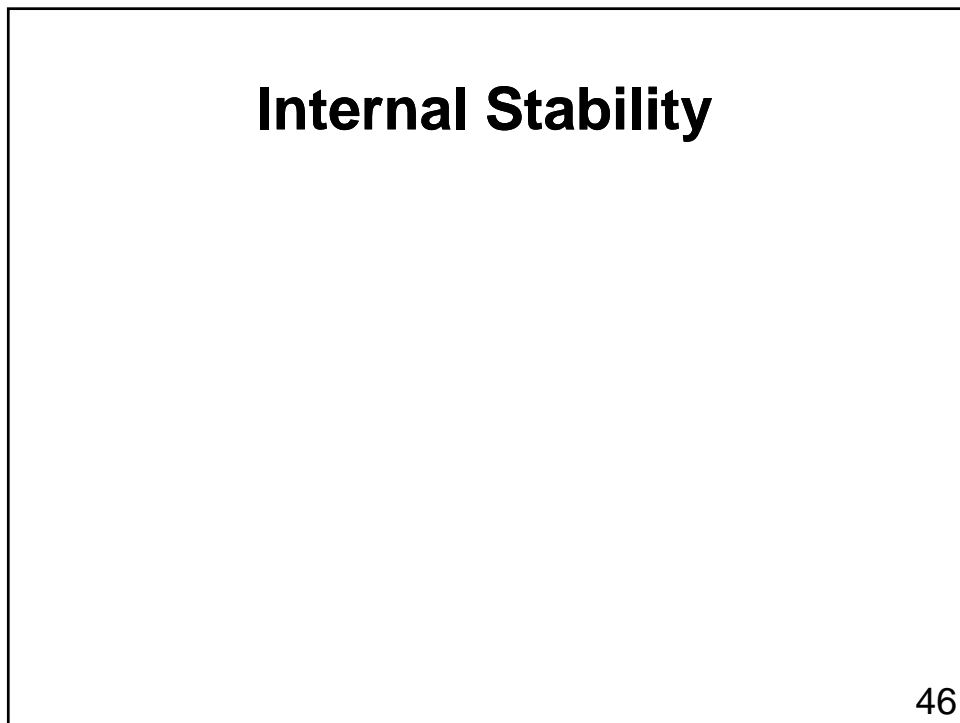
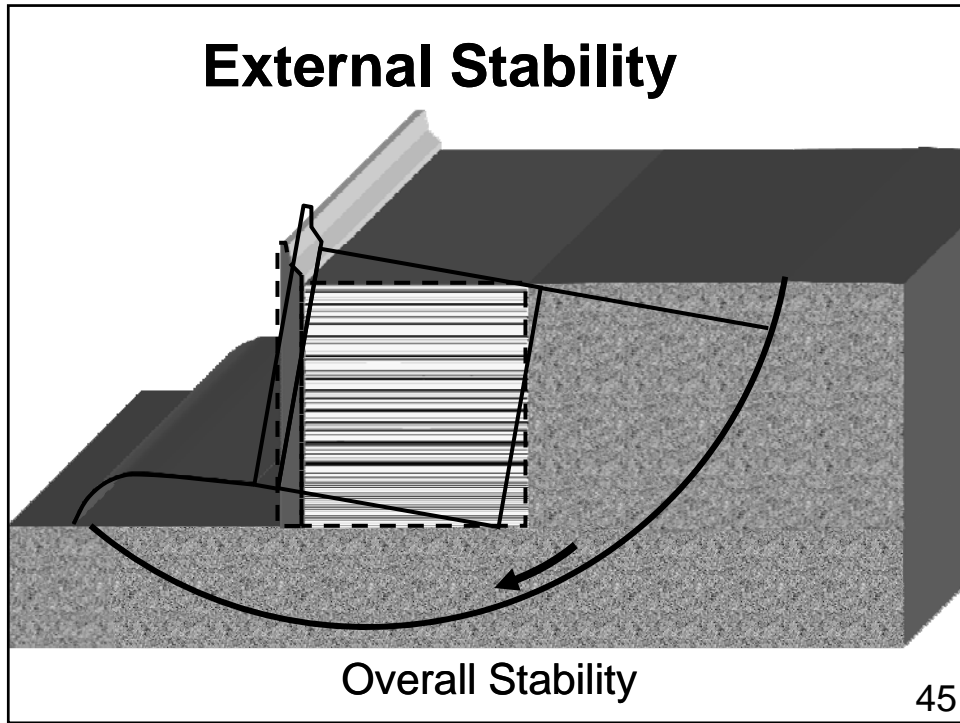

# Internal Stability Reinforcement Failure Modes

- Pull out
- Reinforcement tensile strength
- Connection



47

## Pullout Resistance is developed by:

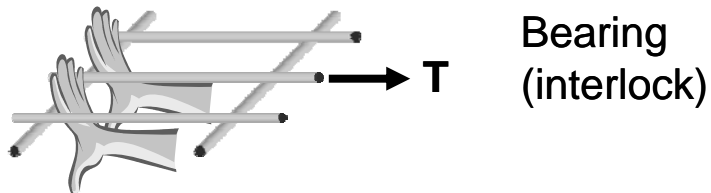
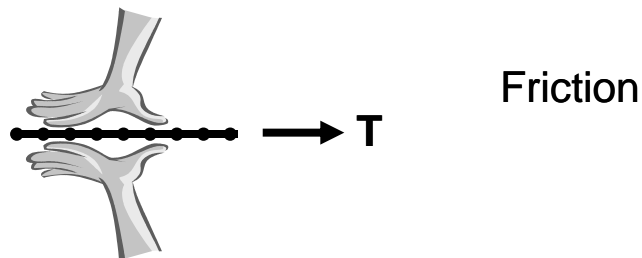

48

## Pullout Resistance testing

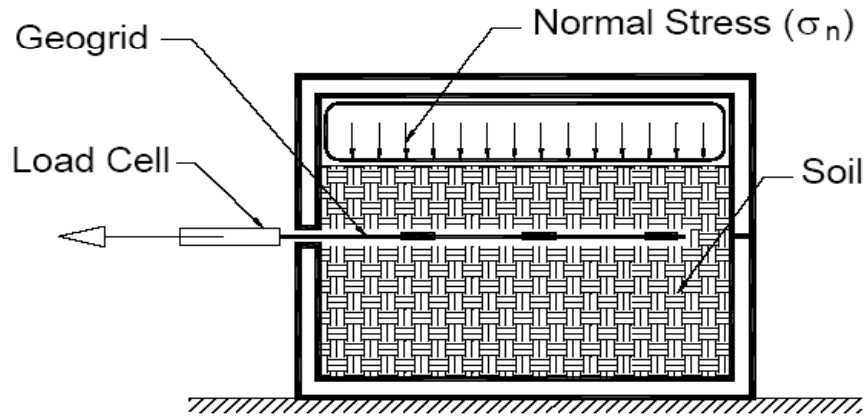

49

## Pull out test demonstration

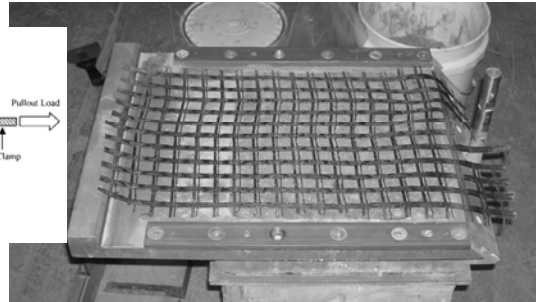
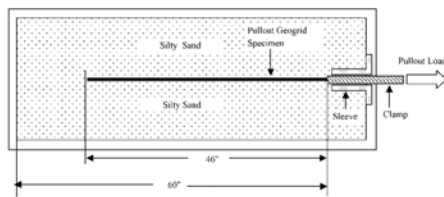

Embedment Length (in.)	Normal Stress (psi)	Pullout Rate (in./min)	Soil Compaction	
			Initial Dry Unit Weight (pcf)	Initial Moisture Content (%)
46.0	2.0	0.04	92.4	17.3

## Pullout Failure

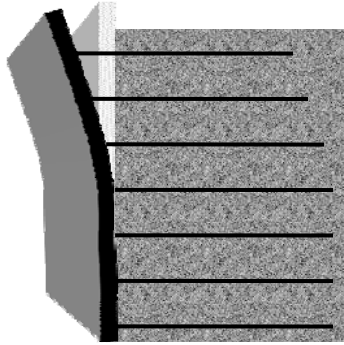

51

## Tensile Strength Test ( $T_{ult}$ )



52

## Typical Testing for Metallic Reinforcing Strength

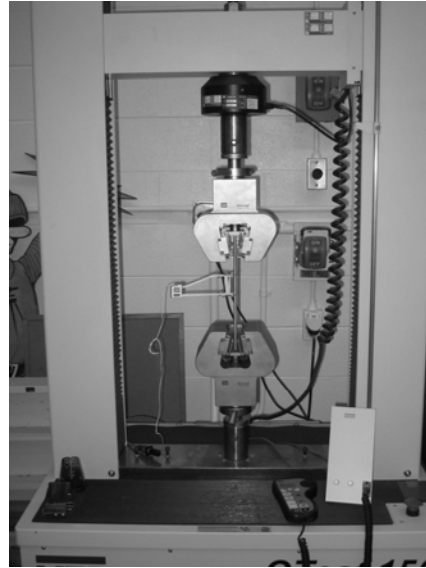

53

## Connection Strength

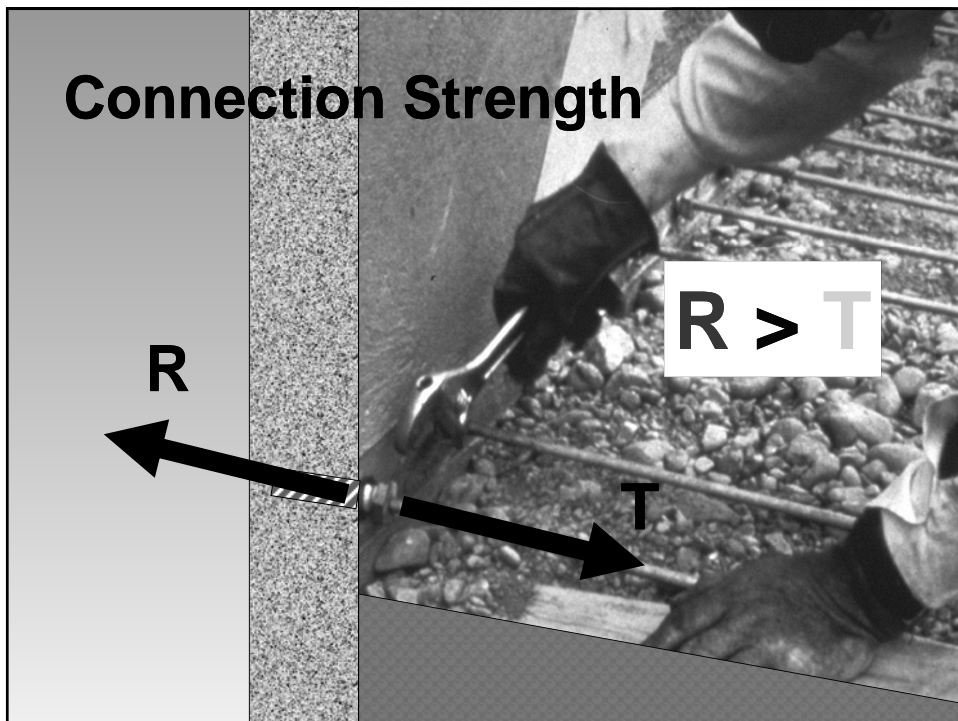

# Plans and Shop Drawings

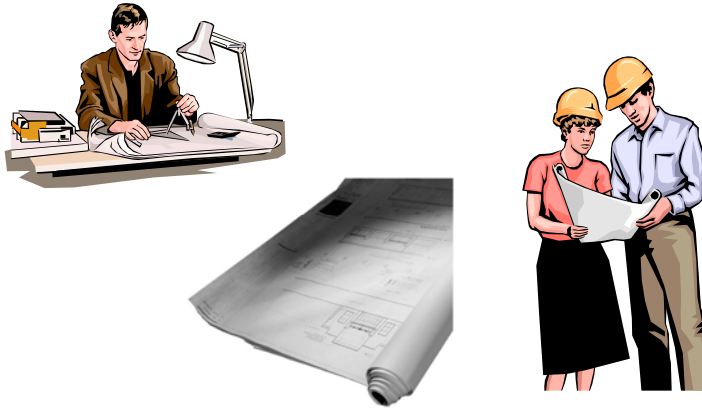

55

**Plan View**

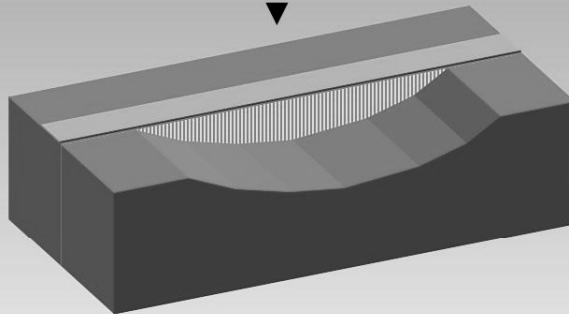
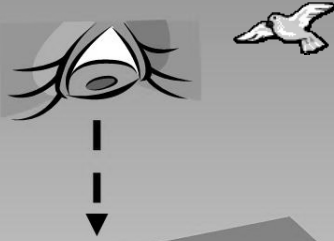

56

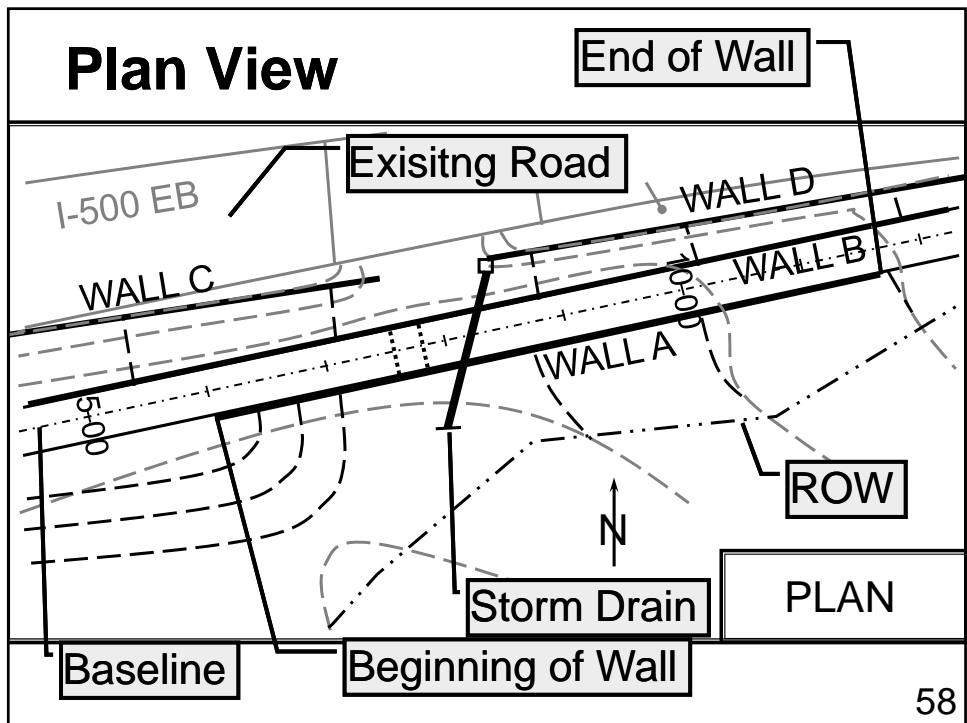
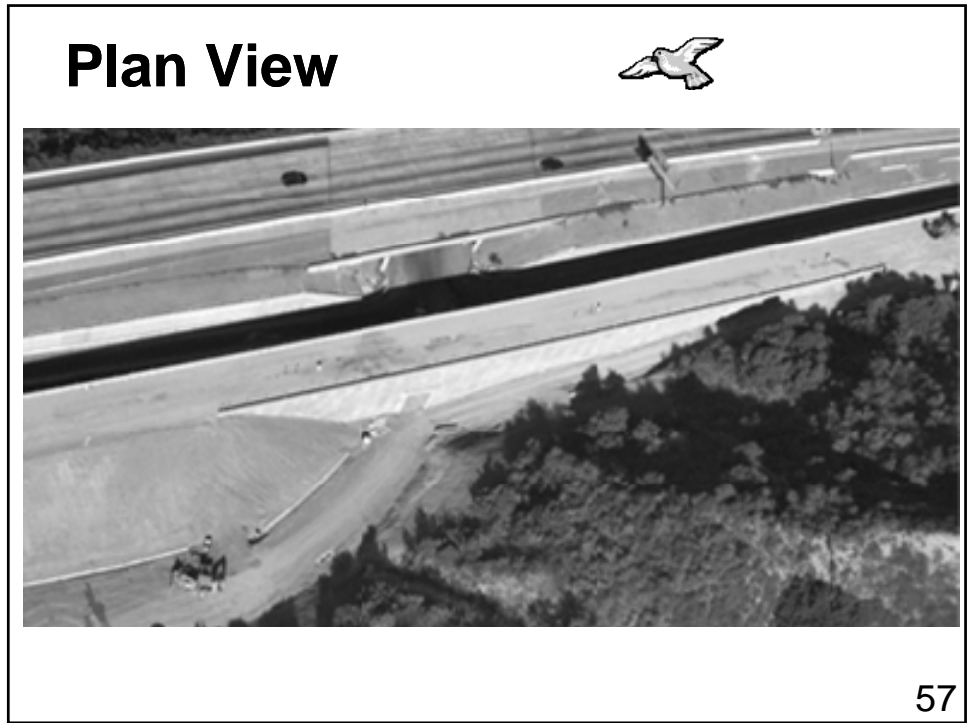

## Elevation View

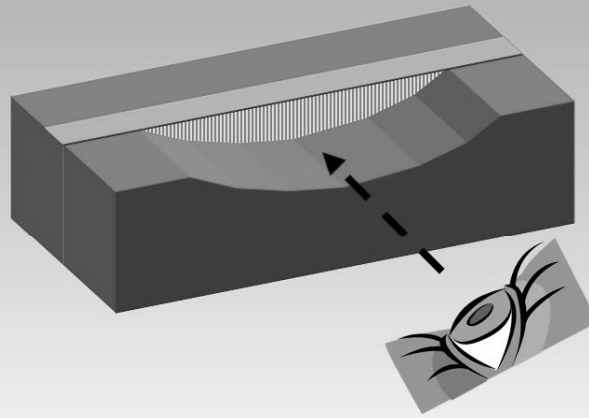

59

## Elevation View



60

## Elevation View

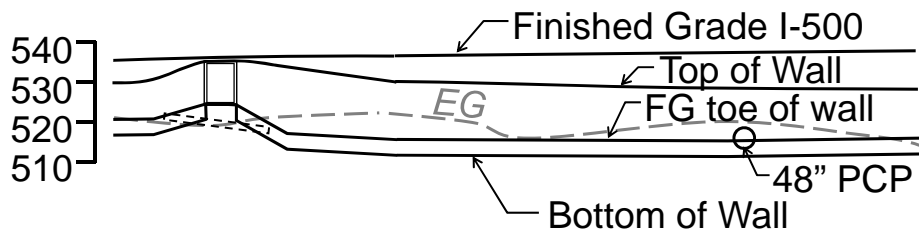

ELEVATION

61

## Cross Section

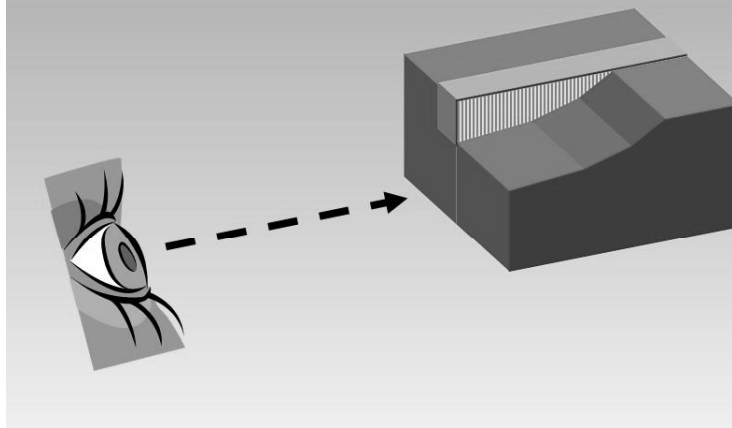

62

## A Typical MSE Wall Cross Section

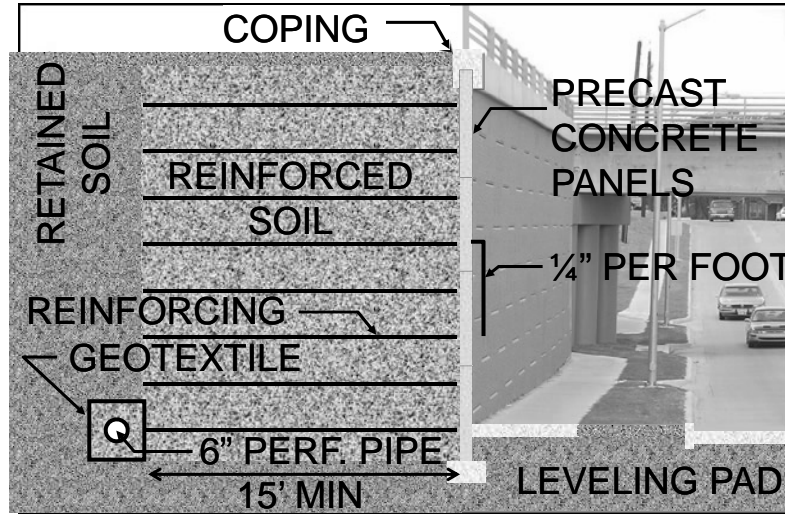

63

## Details

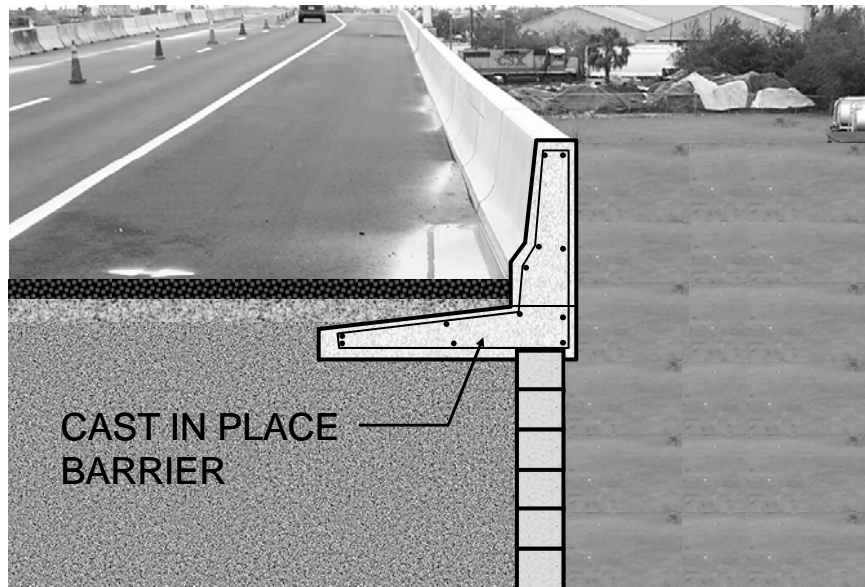

64

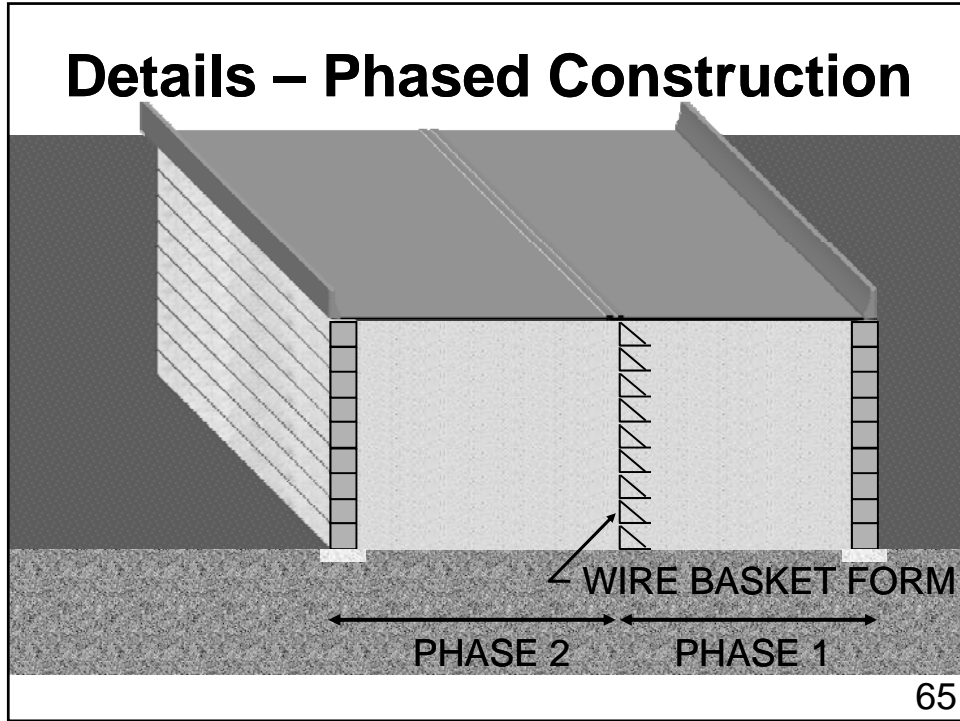

## Details - Two-Stage MSE Wall

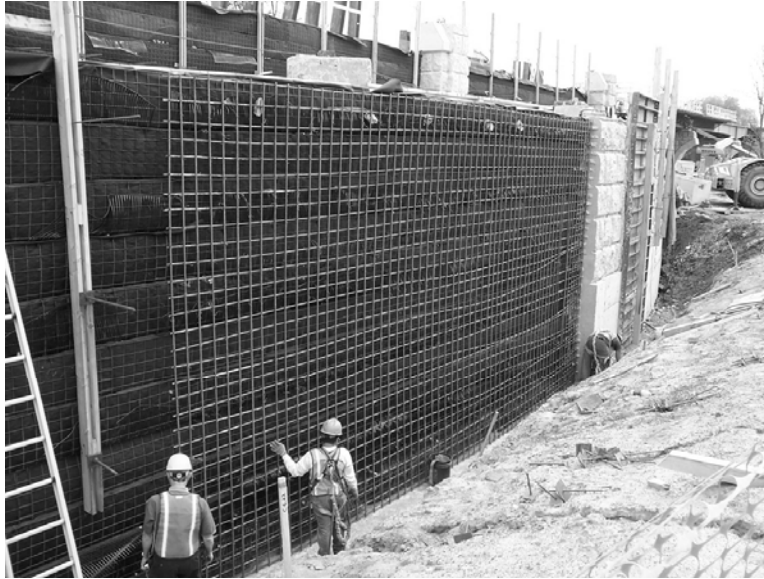

67

## Contract Documents to Shop Drawings

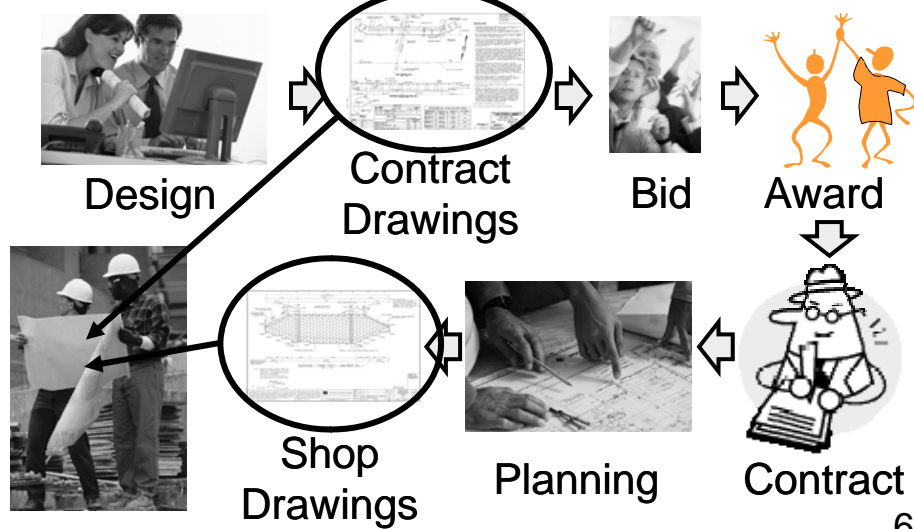

68

## Shop Drawing Includes

- Layout of the System that will effectively retain (reinforce) the earth (slope).
- Complete details of all elements required for the proper construction of the system.



69

## Shop Drawing Includes

- Details of revisions or additions to drainage systems or other facilities required to accommodate the system.
- Other information required in the contract documents.

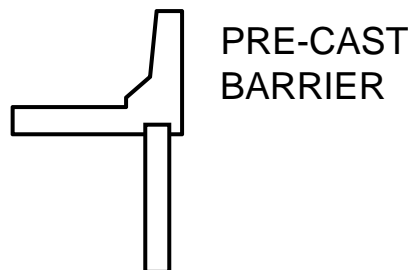

70



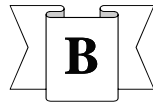

# Drainage

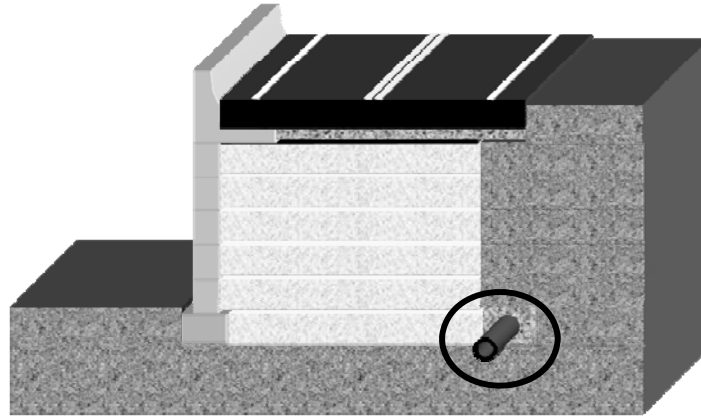

75

# Granular Drain and Pipe

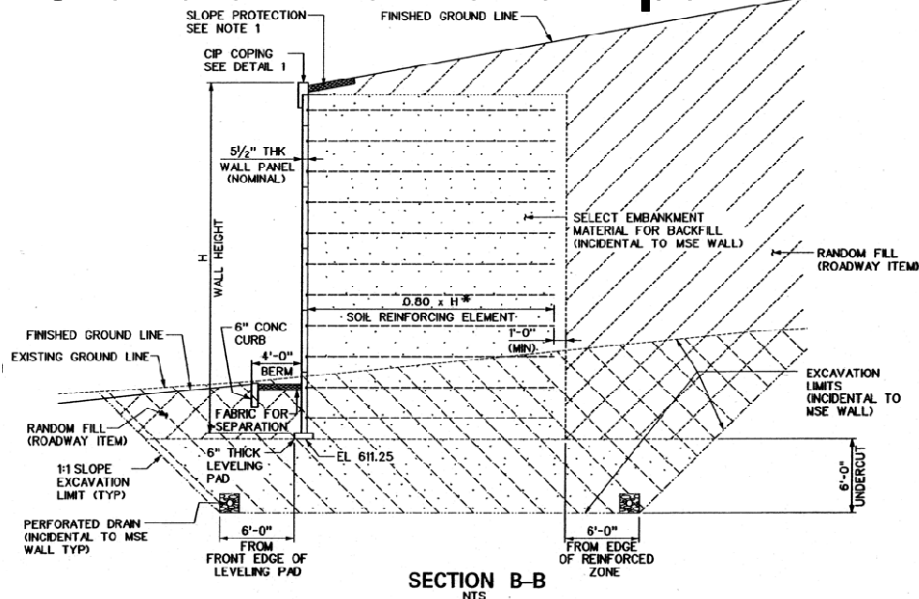

76

## Granular Drain and Pipe



78

## Geo-composite Sheet Drain

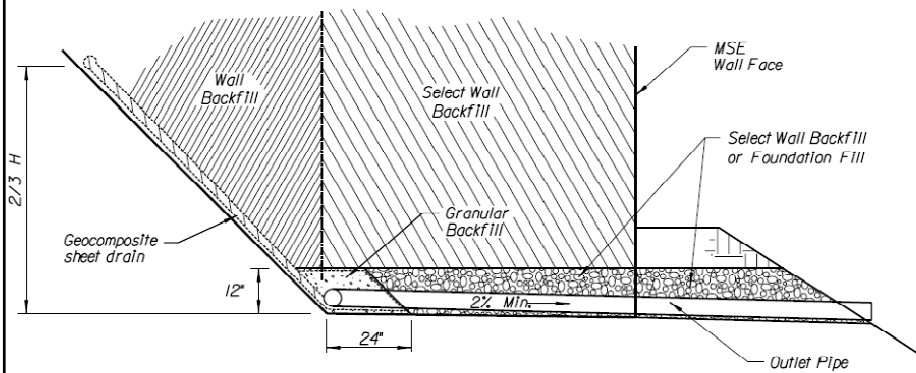

GEOCOMPOSITE SHEET DRAIN  
FOR MSE WALLS

79

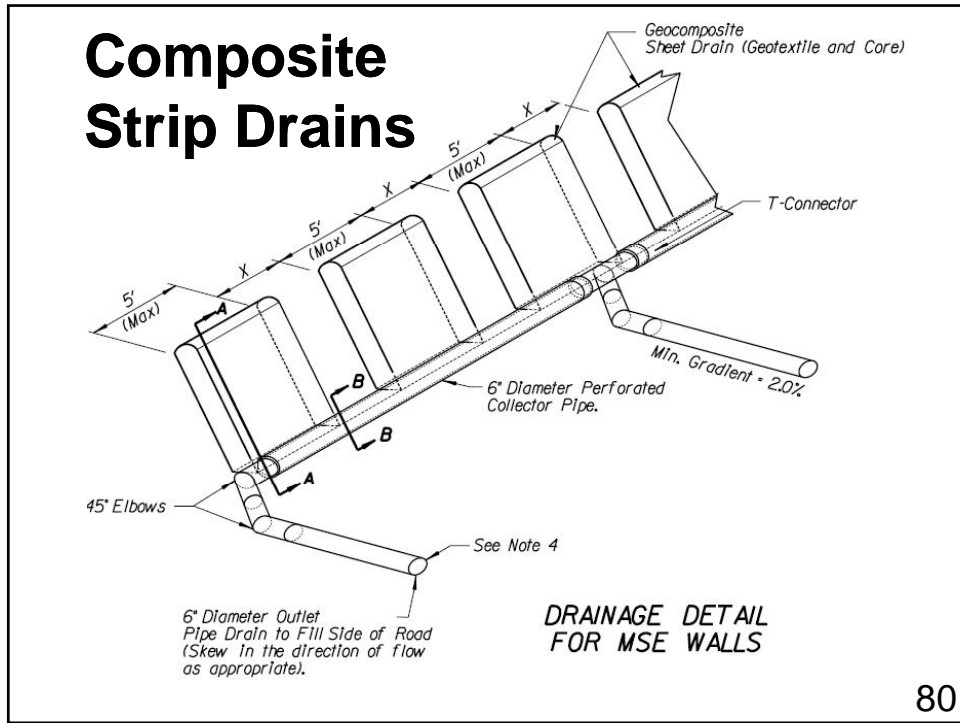

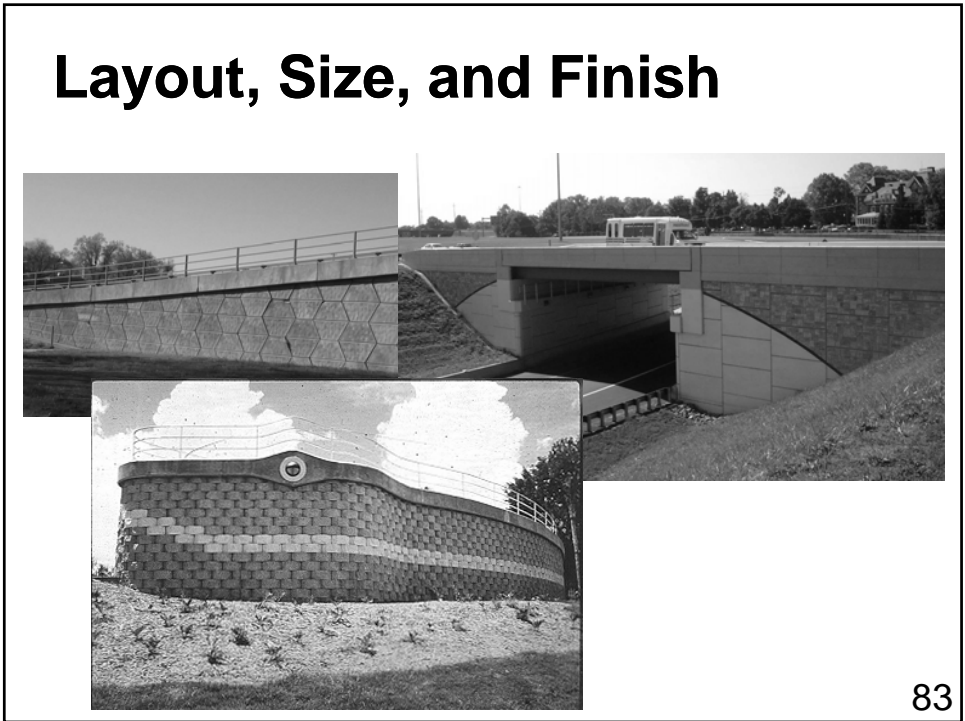
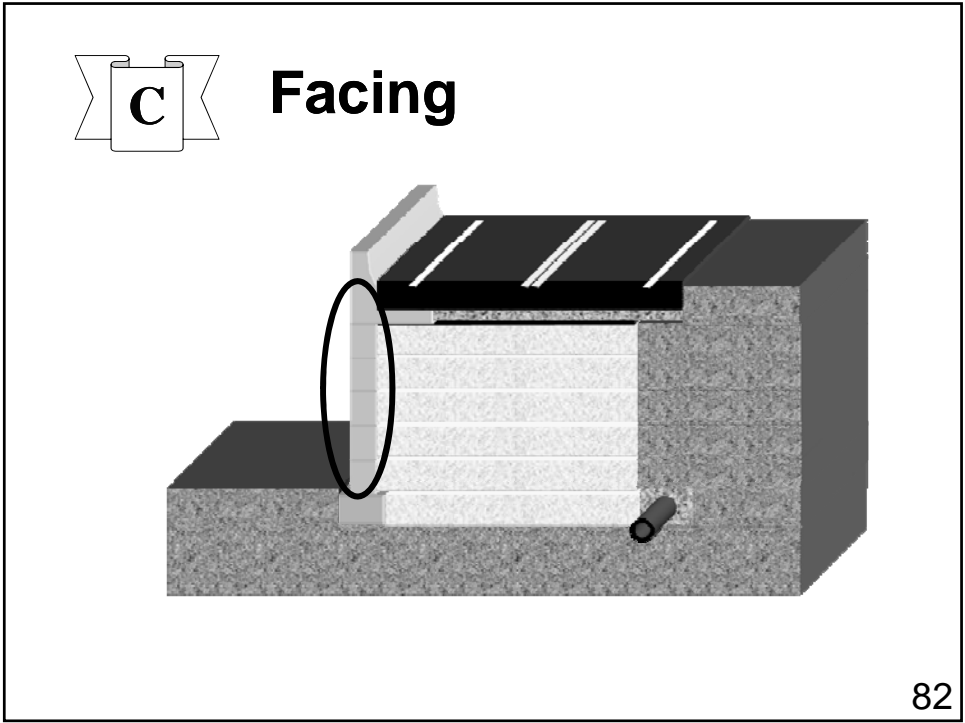



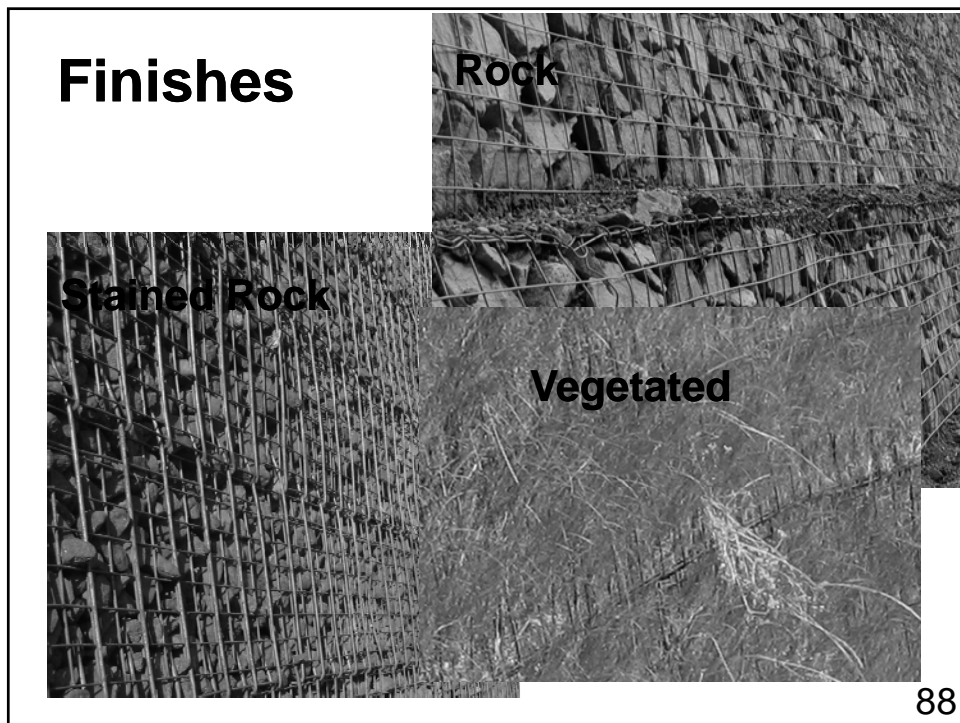
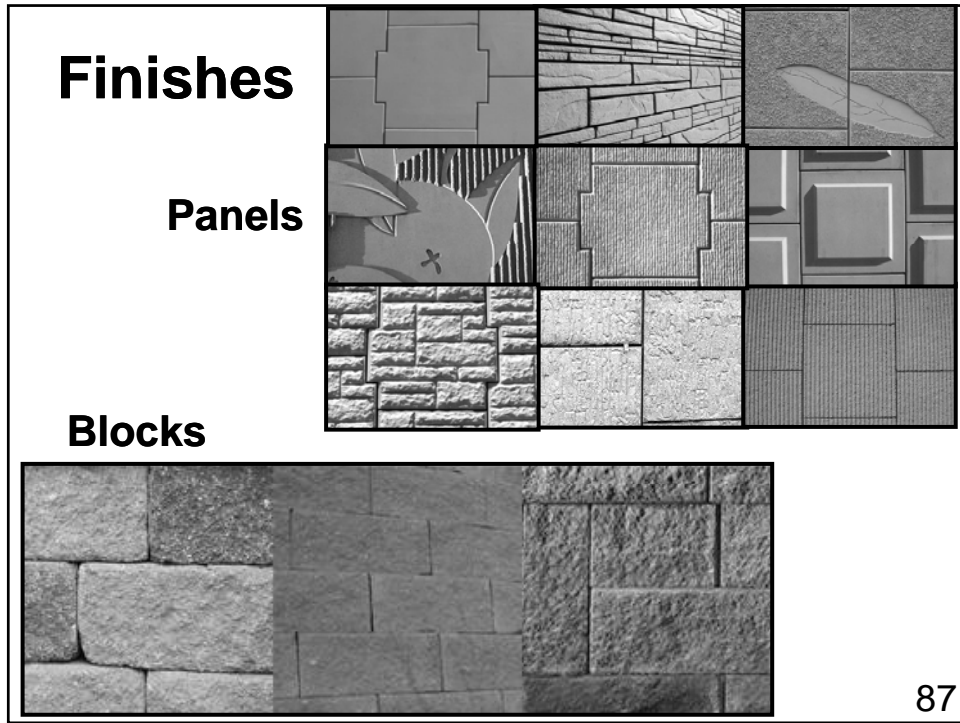

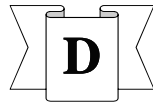

# Reinforcing

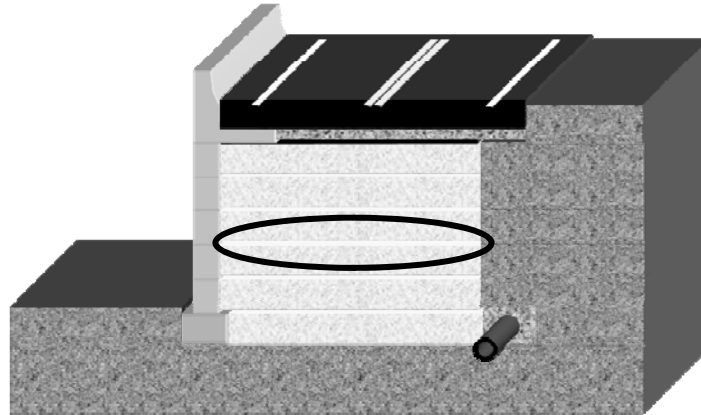

89

## Reinforcing Type, Length, and Spacing

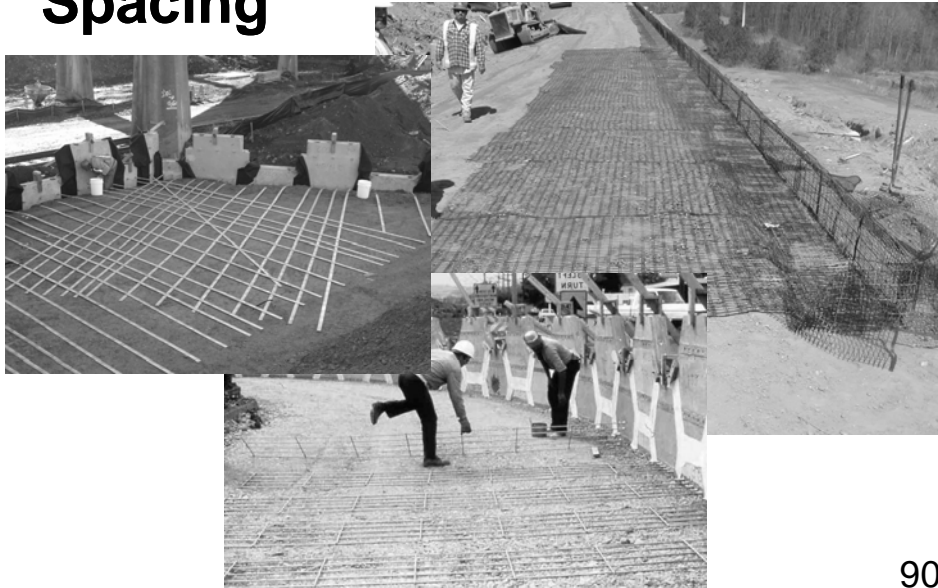

90

# Modular Block

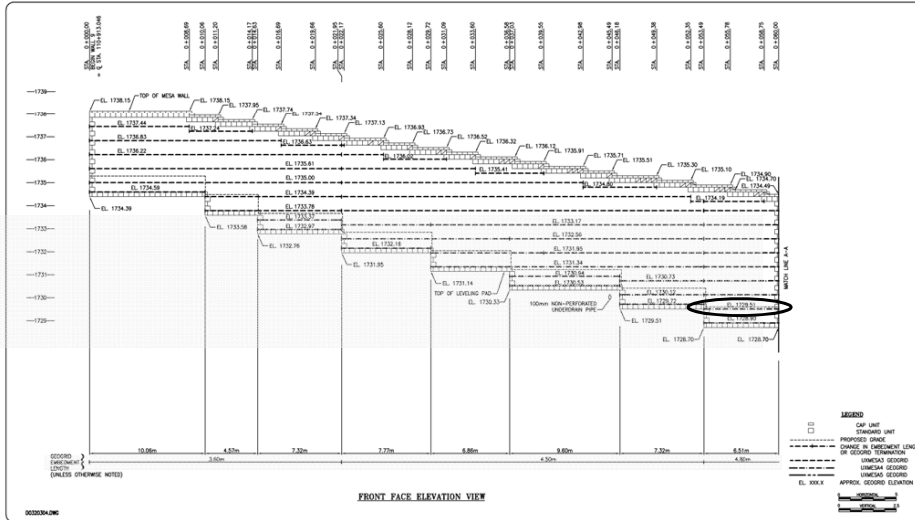

See PW for full size drawing

91

# Connections

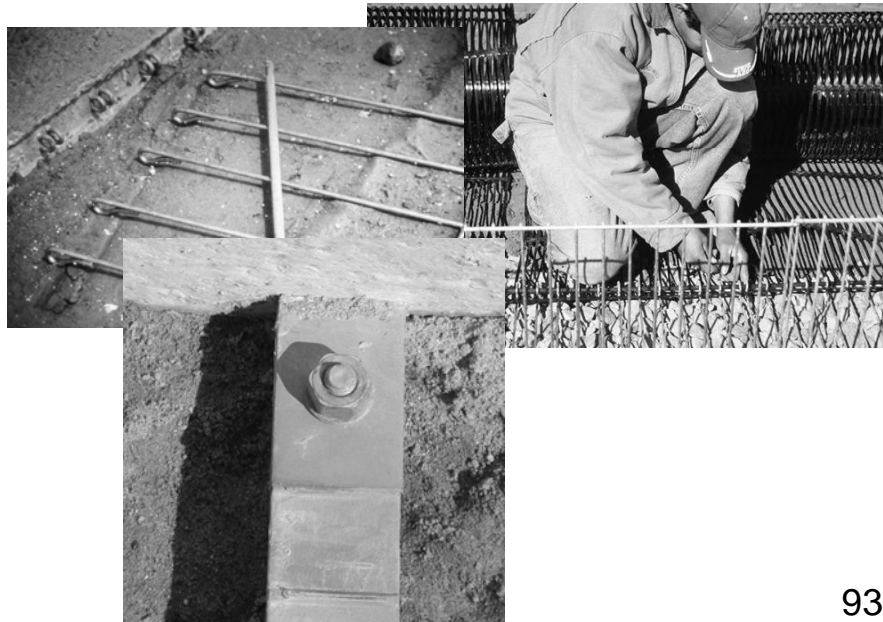

93

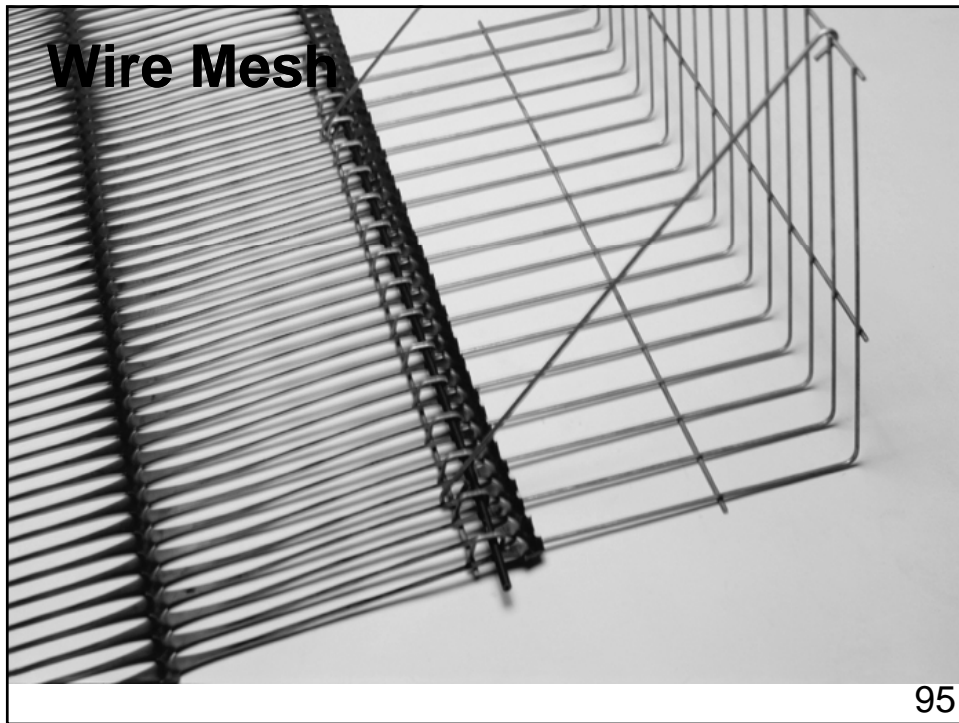
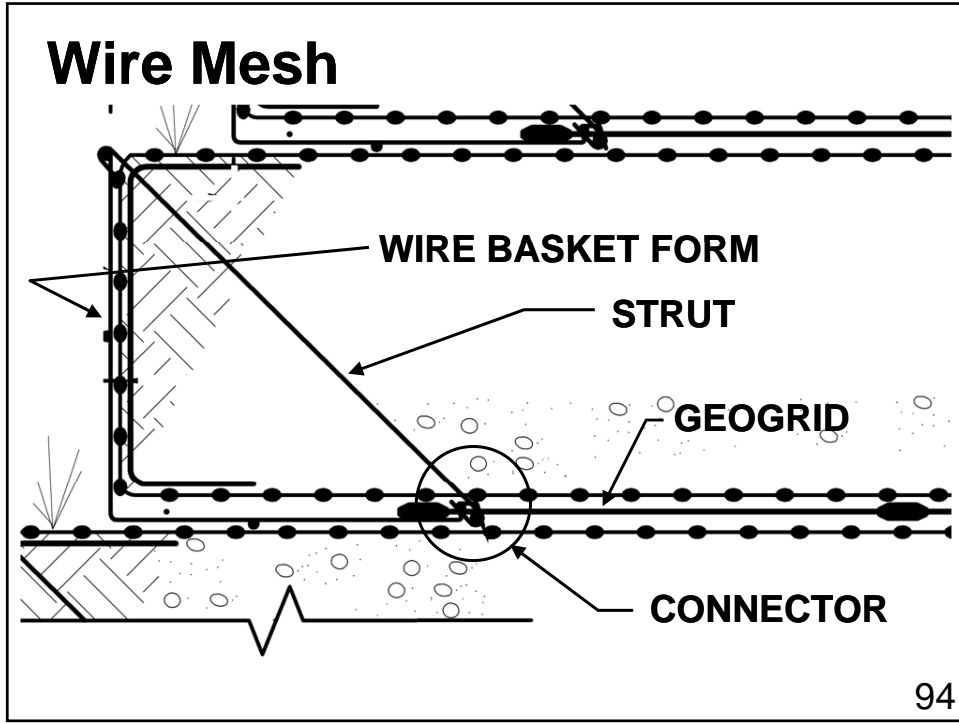

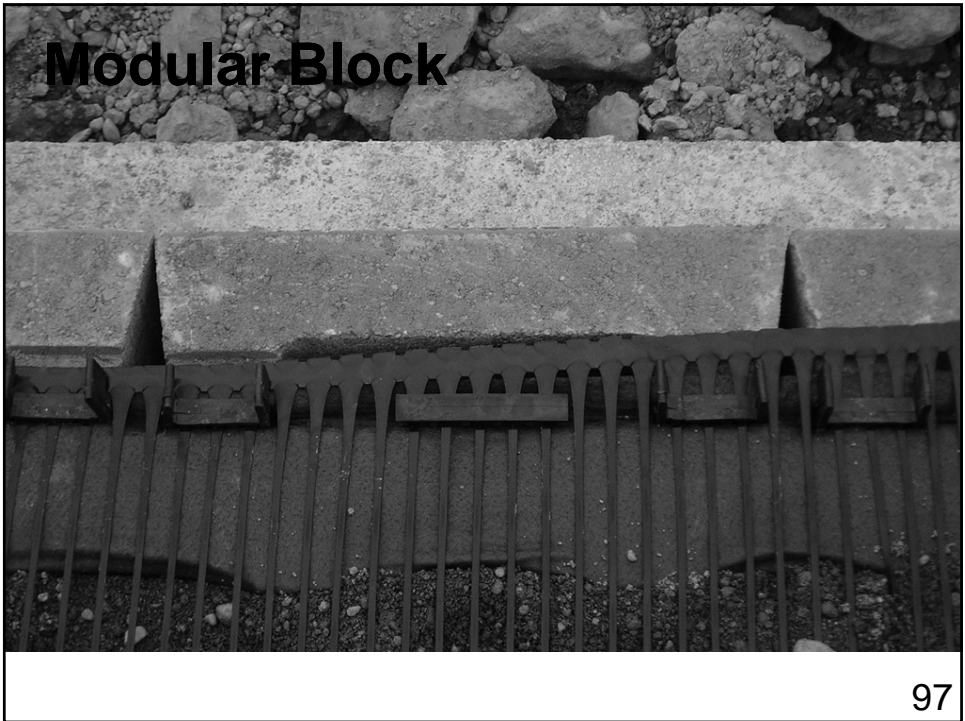
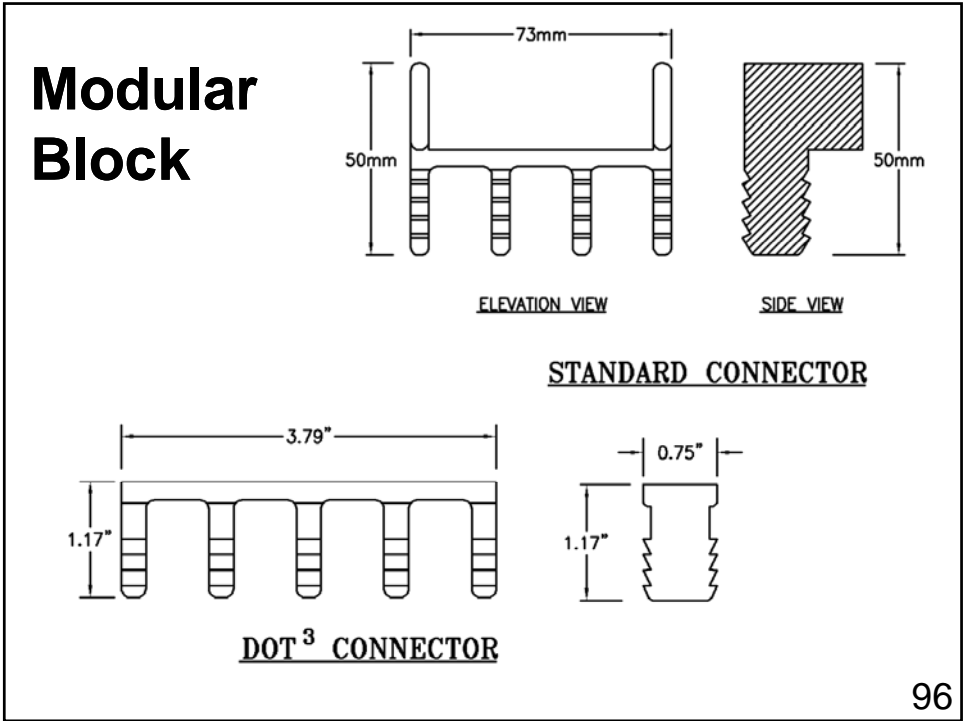

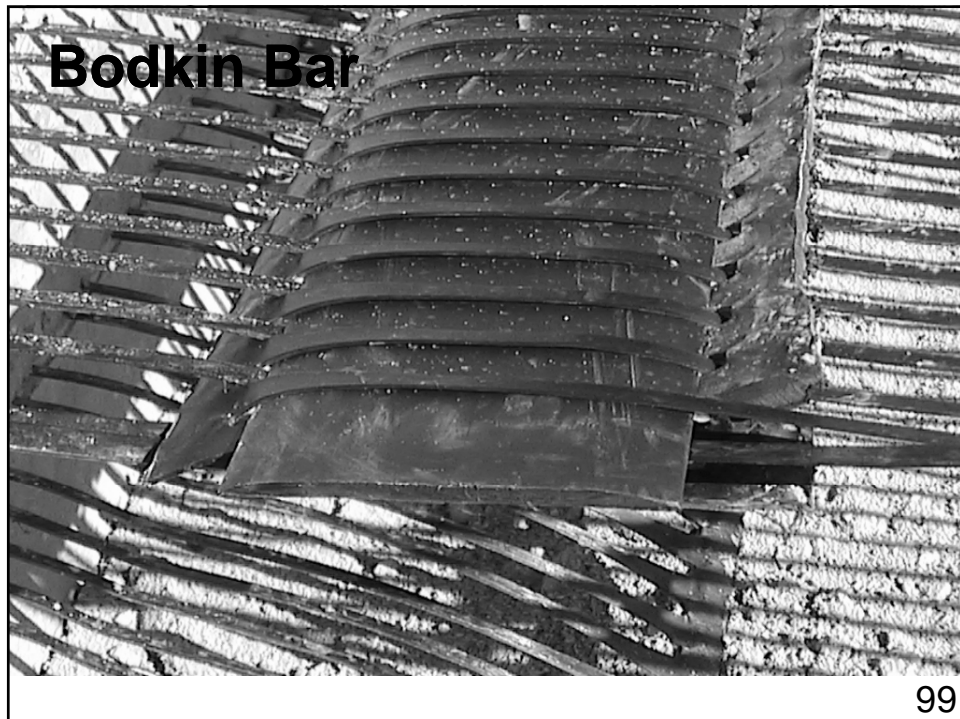
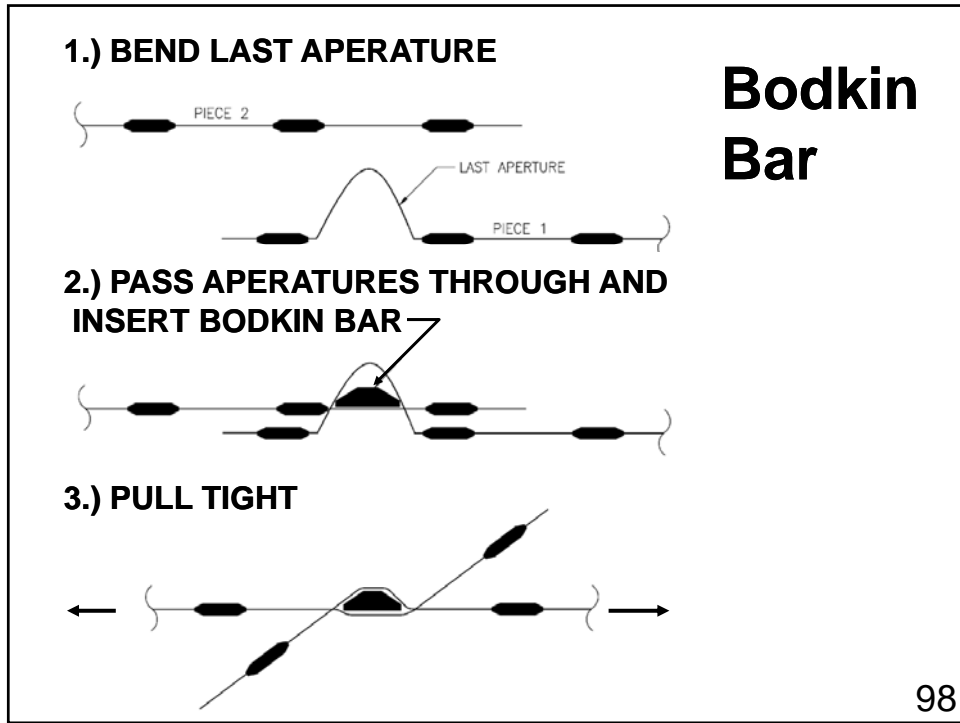

**Obstructions**

- Catch basins/ Inlets/ Manholes
- Parallel pipes
- Deep foundations

100

**Catch Basin**

101

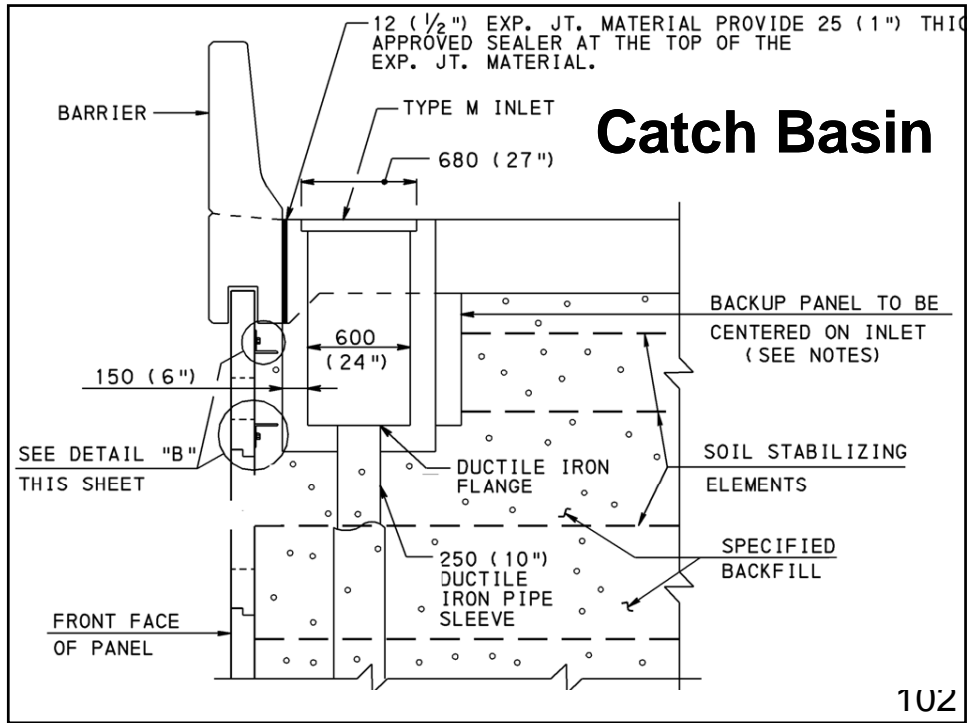

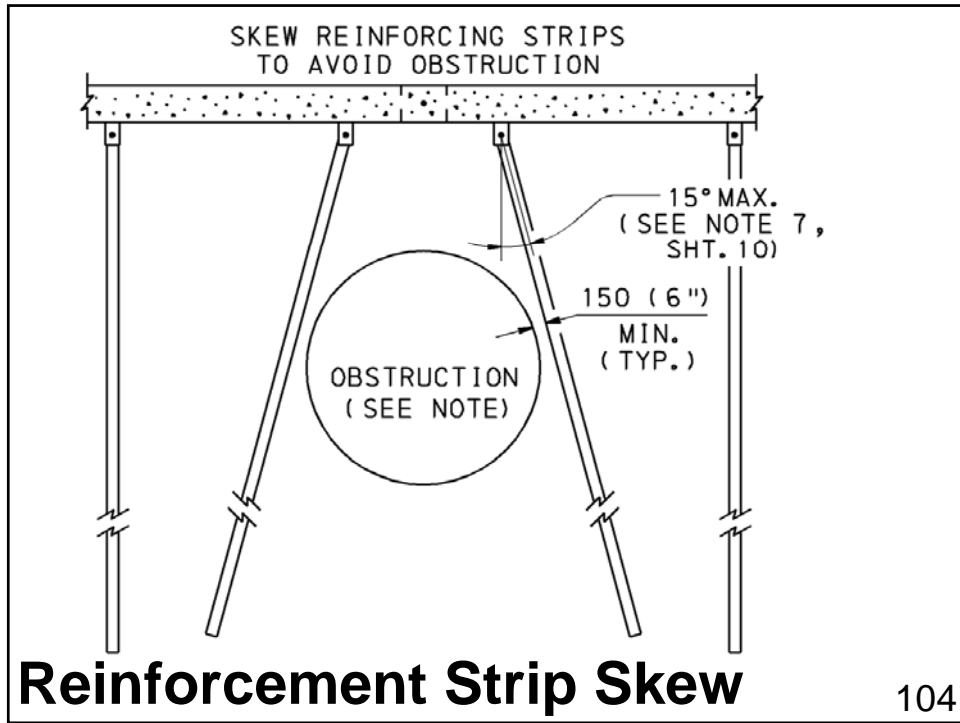

104



105

# Specifications

106

## What's in the specifications

- Scope/ Description/ General  
.....
- Materials or Products  
.....
- Construction or Execution  
.....
- Measurement and Payment  
.....

107

## Scope/ Description/ General

- What's included

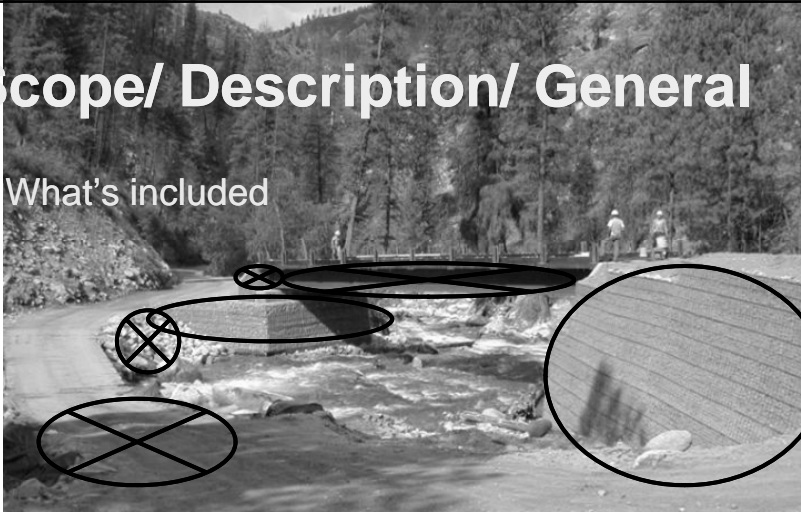

- Administrative requirements



108

## Materials or Products

- What to use

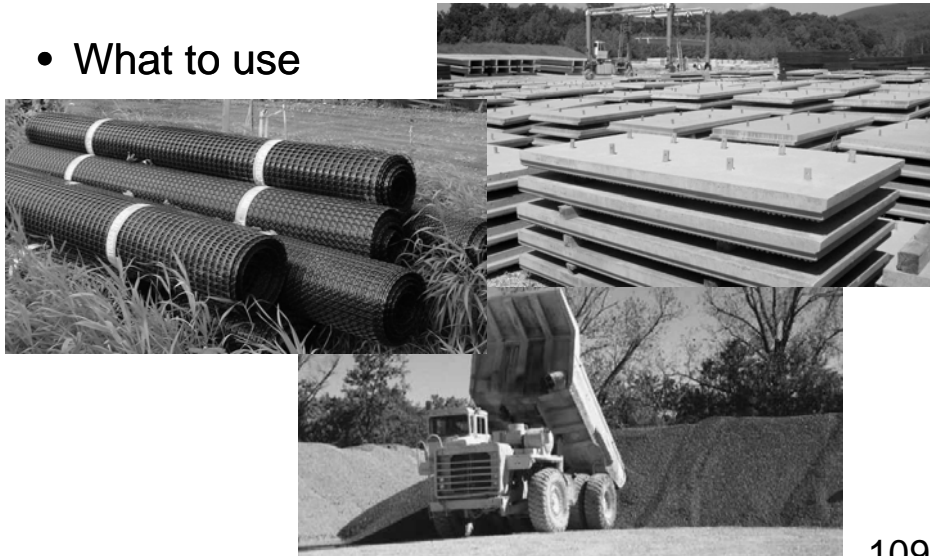

109



## Tensile Strength Test ( $T_{ult}$ )

## MSE and RSS Soil Specifications

- Gradation
- Plasticity
- Strength Requirement
- Electrochemical
  - Resistivity
  - pH
  - Chlorides
  - Sulfates
  - Organic Content



Refer to Page 6.1-16  
**Gradation (Particle Size)**



**Gradation**

Refer to Page 6.1-16

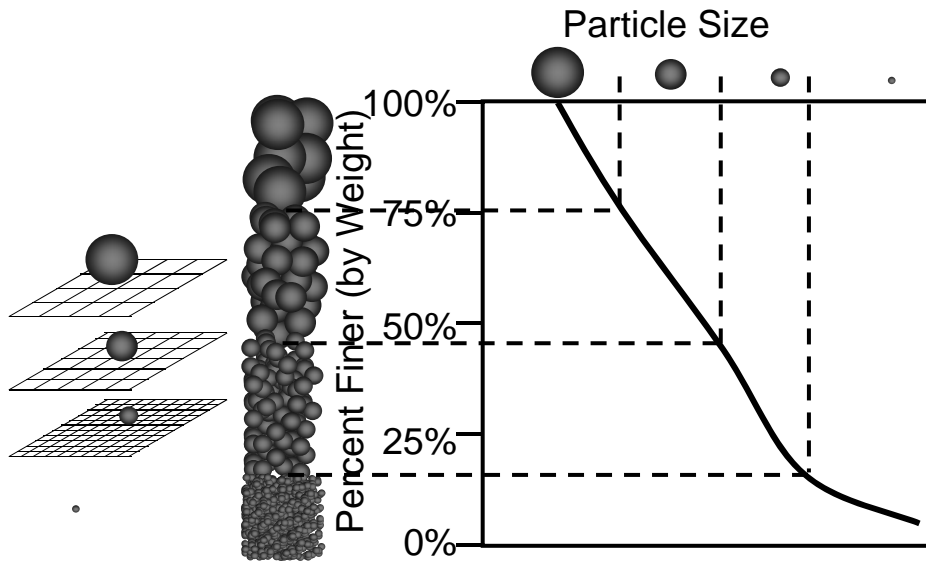

# Construction or Execution

- How to do it

Has anyone read the construction section of the specifications?

114

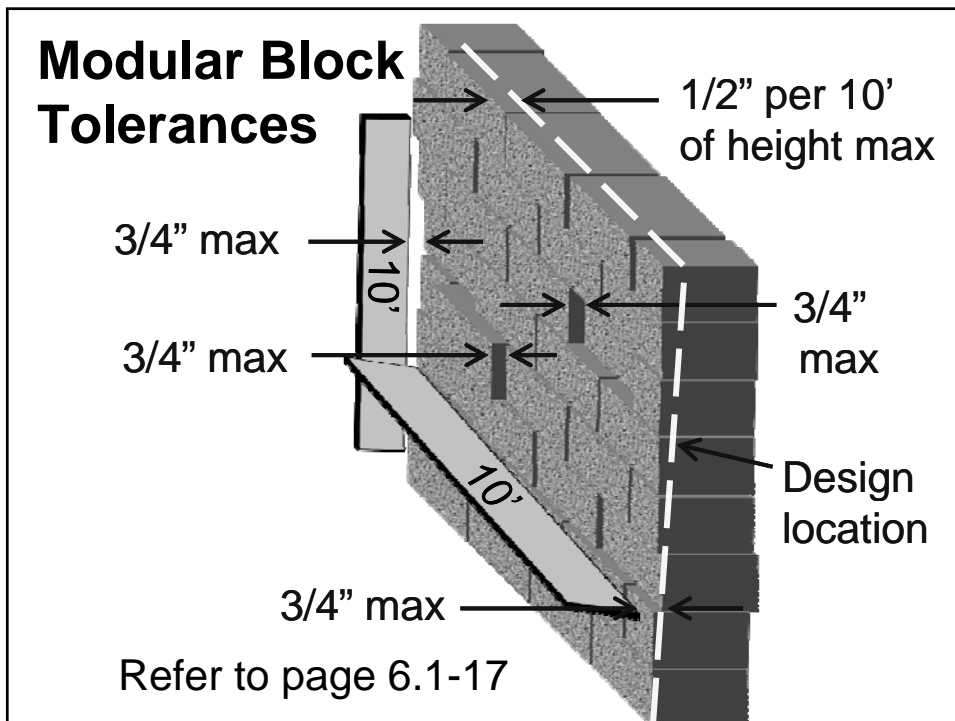

## Inspecting Modular Block



## Spreading Fill Over Reinforcement

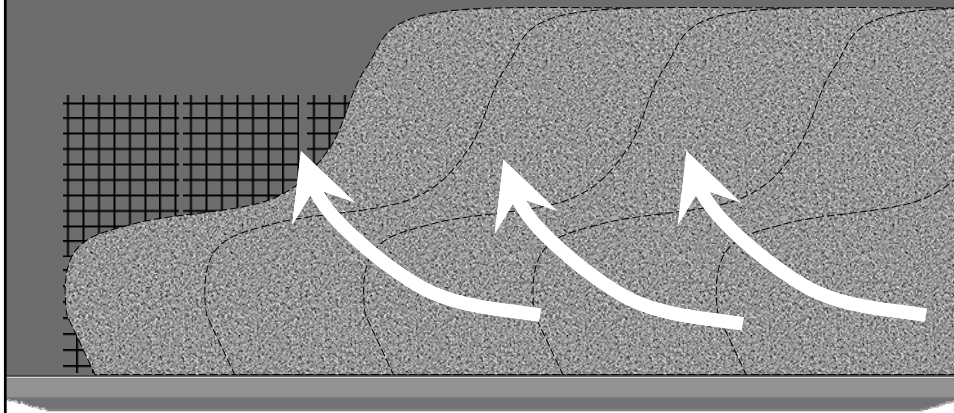

117

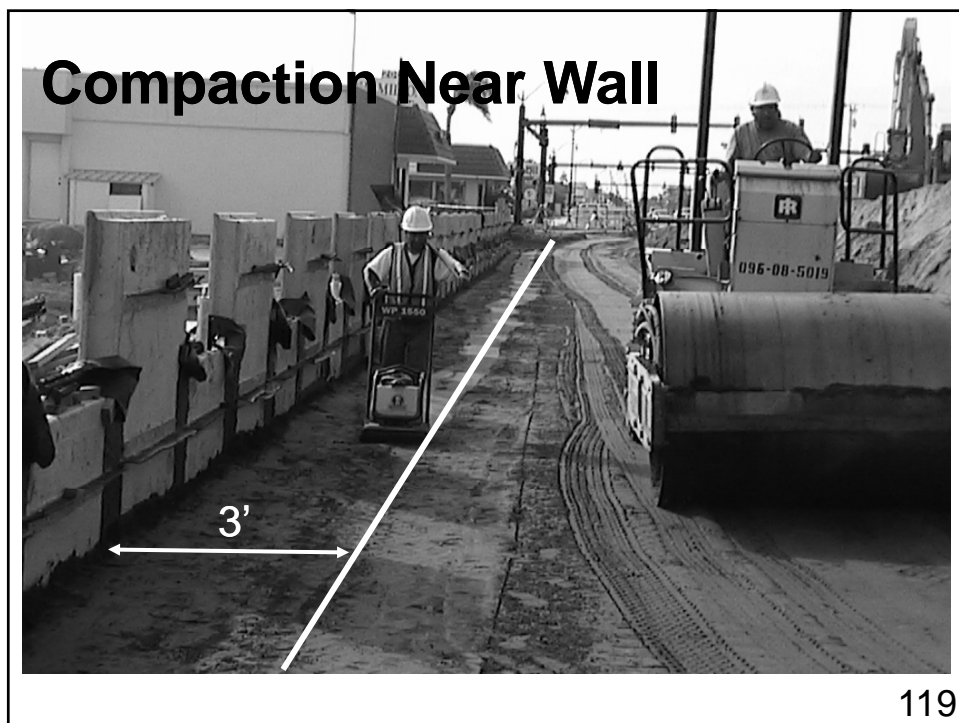

## Measurement and Payment

- How it is paid for

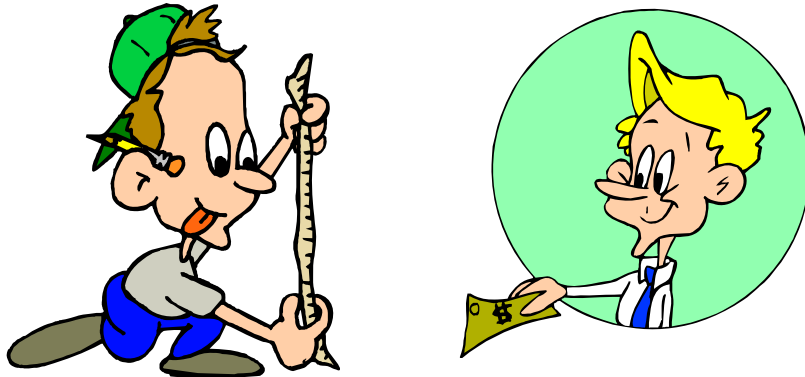

120

## A Document Organization

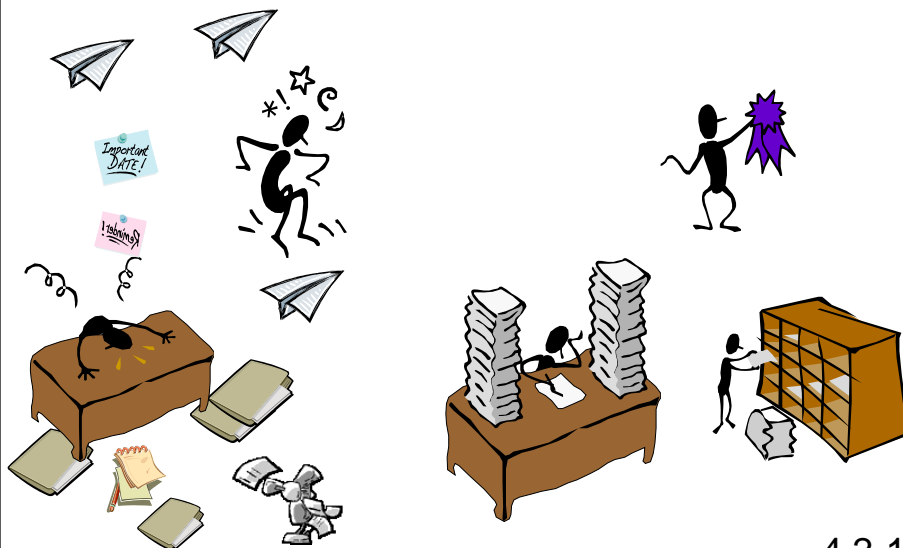

4.2-121

### Poorly Organized Field Trailer



122

### Well-Organized Field Trailer



123

## Well-Labeled Documentation

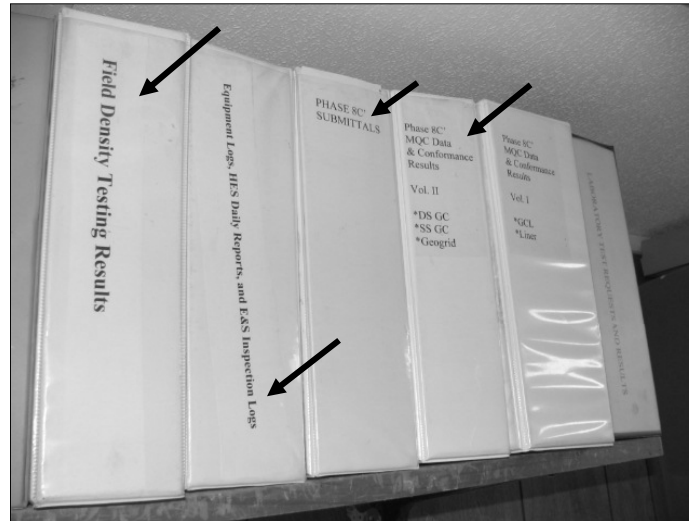

4.2-124

## Documentation Filing

- File-System Organization:
  - Contract Documents
  - Qualifying Submittals
  - Quality Control
  - Quality Assurance
  - Field Inspection
  - Design Clarification/Changes



4.2-125

## Hard-copy Documentation

- All submittals should be dated and kept in chronological order
- Use 3-ring notebook binders
- Label the notebooks

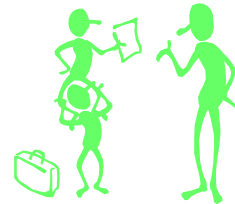

4.2-126

## Electronic Documentation

- Parallel the hard-copy notebooks
- Dated and filed in chronological order
- Make Electronic back-ups !



4.2-127

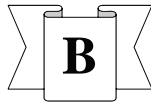

## Tracking Submittals

- Construction Inspector should create a checklist (if not provided) as follows.
  - Search through the specs for required submittals
  - Pay special attention to articles dealing with:
    - Material Properties;
    - Quality Control; and
    - Execution (Installation procedures)



6.1-128

EXAMPLE - SUBMITTAL CHECKLIST			
SPEC SECTION & ARTICLE	DESCRIPTION OF SUBMITTAL	TO BE SUBMITTED BY	SUBMITTAL DUE
P 6.1-12	Working Drawings	Contractor	>4 weeks before work begins
P 6.1-14 And P 6.1-16	Certification of Concrete for facing	Contractor	Before use
P 6.1-15 And P 6.1-16	Certification of reinforcing	Contractor	Before use
P 6.1-16	Certification of joint materials	Contractor	Before use
P 6.1-16	Certification of backfill	Contractor	Before use
P 6.1-16	Certification of leveling pad concrete	Contractor	Before use

**See page 6.1-48**

6.1-129

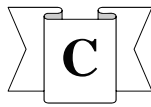

## Alternate Submittals, Design Clarifications, and Change Orders



6.4-130

## **Definition** Alternate Submittal

- Expressly allowed for in the Specs
- Submitted by the Contractor or Manufacturer to:
  - Facilitate procurement of materials,
  - Ease construction, or
  - Increase quality of the end product
- Usually does not lead to a Change Order



6.4-131

## **Definition** Design Clarification

- Often requested by the contractor
- Provided by the Engineer to clarify the Drawings or Specifications
- May or may not lead to a Change Order

Example on page 6.4-6



6.4-132

## **Definition** Change Order

- Provided by the Engineer or Construction Division Manager to modify the:
  - Drawings;
  - Specifications; or
  - Contract Terms
- Often results in a change in contract price and/or schedule



Example on page 6.4-8

6.4-134

## Administering Alternate Submittals



- The Construction Inspector must:
  1. Ensure alternate submittal is allowed
  2. Ensure supporting information is provided
  3. Send to the Designer in a timely manner
  4. Follow up with Designer – then respond to the Contractor in a timely manner
  5. Ensure full understanding of whether a Change Order will be required

6.4-136

## Administering Design Clarifications

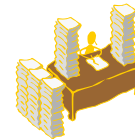

- The Construction Inspector must:
  1. Ensure clarity and completeness
  2. Send to the Designer in a timely manner
  3. Follow up with Designer - respond to the Contractor
  4. Ensure understanding of whether a Change Order will be required

6.4-137

## Documentation

Response: Revision 1 of Specification 02220 – Article 2.08A has been corrected such that all gpc references to D698 have been changed to D1557. A copy of the effected page is attached at 01A

Section 02220: Mechanically Stabilized Earth (MSE) Berm

**2.08 MSE BERM SOIL PROPERTIES**

A. MSE Berm Soil shall meet the requirements set forth in Section 02200 Granular Fill. The MSE Berm soil shall be defined as retained soil (i.e., that soil behind the reinforcement zone), and reinforced soil (i.e., that soil within the reinforced zone of the MSE Berm). In addition, MSE Berm soil:

1. Shall exhibit an effective angle of internal friction of at least 32° for retained soil, and 32° for reinforced soil when tested in accordance with ASTM D 4767 at consolidation pressures of 500, 1,500, and 4,000 psf, and remolded to 95 percent  $\pm 1$  pcf of the ~~standard~~ <sup>modified</sup> Proctor maximum dry density (ASTM D ~~698~~) at -4 to +1 percent of the optimum moisture content (ASTM D ~~598~~).
2. Shall exhibit a maximum moist unit weight of 120 pounds per cubic foot when compacted to 98 percent of the ~~ASTM D-698~~ <sup>modified</sup> (standard Proctor) maximum dry density at the optimum moisture content.

6.4-139

## Administering Change Orders

- The Construction Inspector must:
  1. Ensure clarity and completeness
  2. Send to Designer in a timely manner
  3. Inform the Contract Administrator
  4. Ensure understanding of changes to contract price
  5. Ensure understanding of changes to construction schedule.

6.4-140

# Homework

- Use the contract plans, shop drawings and specifications in the handout to answer the questions.

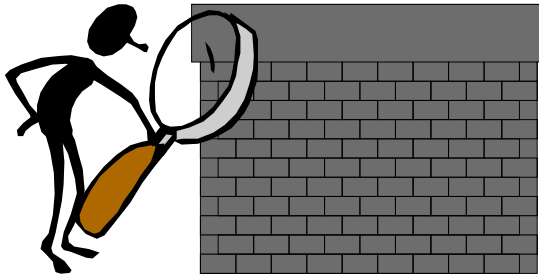

141